



GAI-TRONICS® CORPORATION
A HUBBELL COMPANY

Model 13350 and 13351 Integral Loudspeakers

Confidentiality Notice

This manual is provided solely as an operational, installation, and maintenance guide and contains sensitive business and technical information that is confidential and proprietary to GAI-Tronics. GAI-Tronics retains all intellectual property and other rights in or to the information contained herein, and such information may only be used in connection with the operation of your GAI-Tronics product or system. This manual may not be disclosed in any form, in whole or in part, directly or indirectly, to any third party.

Installation

Mounting

1. Remove the rear enclosure from the carton.
2. There are four 0.280-inch mounting holes located in the four corners of the enclosure. Refer to Figure 2 or 3 for mounting details.

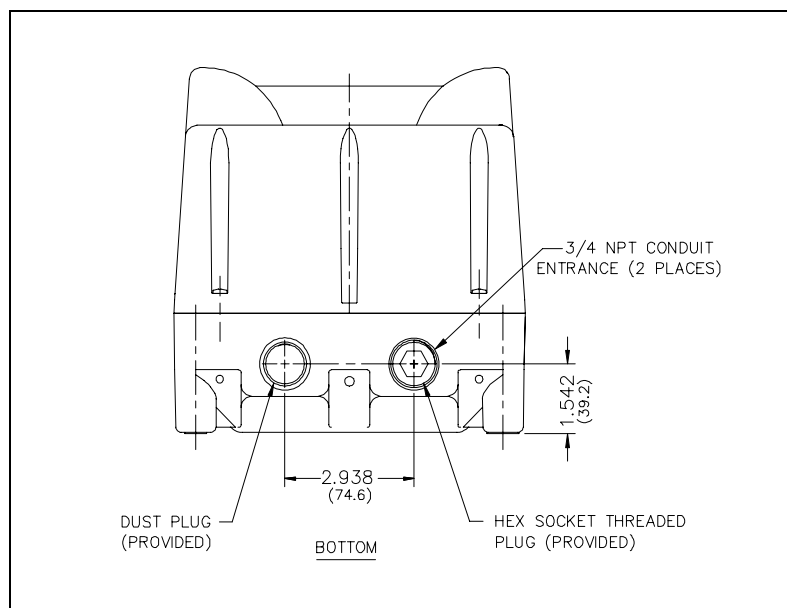

Figure 1. Conduit Entries

Wiring

Model 13350

The rear enclosure contains a two-position terminal block. Field connections are made directly on this block. The rear enclosure of the loudspeaker allows versatile placement because it is fully “reversible” with the front horn enclosure. The unit is shipped assembled for bottom cable entry. If top cable entry is desired, rotate the rear enclosure 180 degrees to move the terminal block to the opposite mounting position. The screws should be installed and tightened to 10 to 14 in-lbs. torque.

The two 3/4-inch conduit entries (female) allow speakers to be easily “daisy-chained” without junction boxes. The installer can terminate to the speaker with rigid conduit, flexible conduit, or cable bushing. A 3/4-inch male hex socket-type conduit plug is provided when only one conduit entry is used. When conduit entries are closed, the speaker is completely weatherproof.

After connecting the conduit to the enclosure, connect the speaker wire to the appropriate terminal blocks. Refer to Figure 2. Then plug the “quick connect” terminals from the front section of the speaker into the appropriate terminal blocks. Close the speaker and tighten front panel screws to 16 to 20 in-lbs. torque.

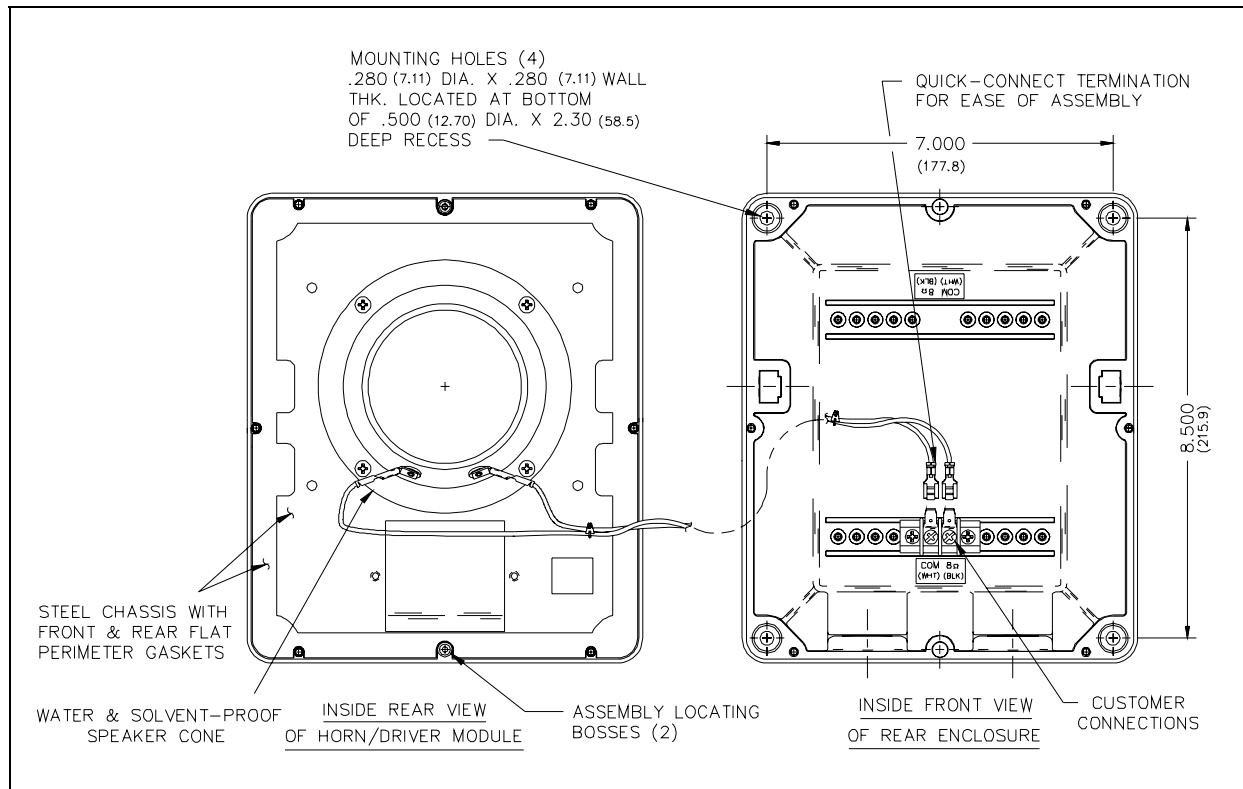

Figure 2. Model 13350 Loudspeaker Wiring

NOTE: If the conduit entries are positioned at the top of the enclosure, and hollow 3/4-inch conduit is used, entries to the enclosure should be internally plugged using a suitable sealant to avoid condensation collecting within the enclosure.

Model 13351

The rear enclosure contains a six-position terminal block. Field connections and wattage tap changes are made directly on this block; the block is equipped with a wiring harness that connects to the loudspeaker. The rear enclosure of the loudspeaker allows versatile placement because it is fully “reversible”. The unit is shipped assembled for bottom cable entry. If top cable entry is desired, rotate the rear enclosure 180 degrees to move the terminal blocks to the opposite mounting position. Tighten the screws on the terminal blocks to 10 to 14 in-lbs. torque.

The 3/4-inch conduit entries (female) allow speakers to be easily “daisy-chained” without junction boxes. This is particularly desirable in 70-volt distributed systems. The installer may terminate to the speaker with rigid conduit, flexible conduit, or cable bushing. A 3/4-inch male hex socket type conduit plug is provided when only one conduit entry is used. Once conduit entries are closed the speaker is completely weatherproof.

After connecting the conduit to the enclosure, connect the speaker wire to the appropriate terminal blocks. Refer to Figure 3. Then plug the connector on the rear enclosure to the mating connector on the front section. Close the speaker and tighten the front panel captive screws to 16 to 20 in-lbs. torque.

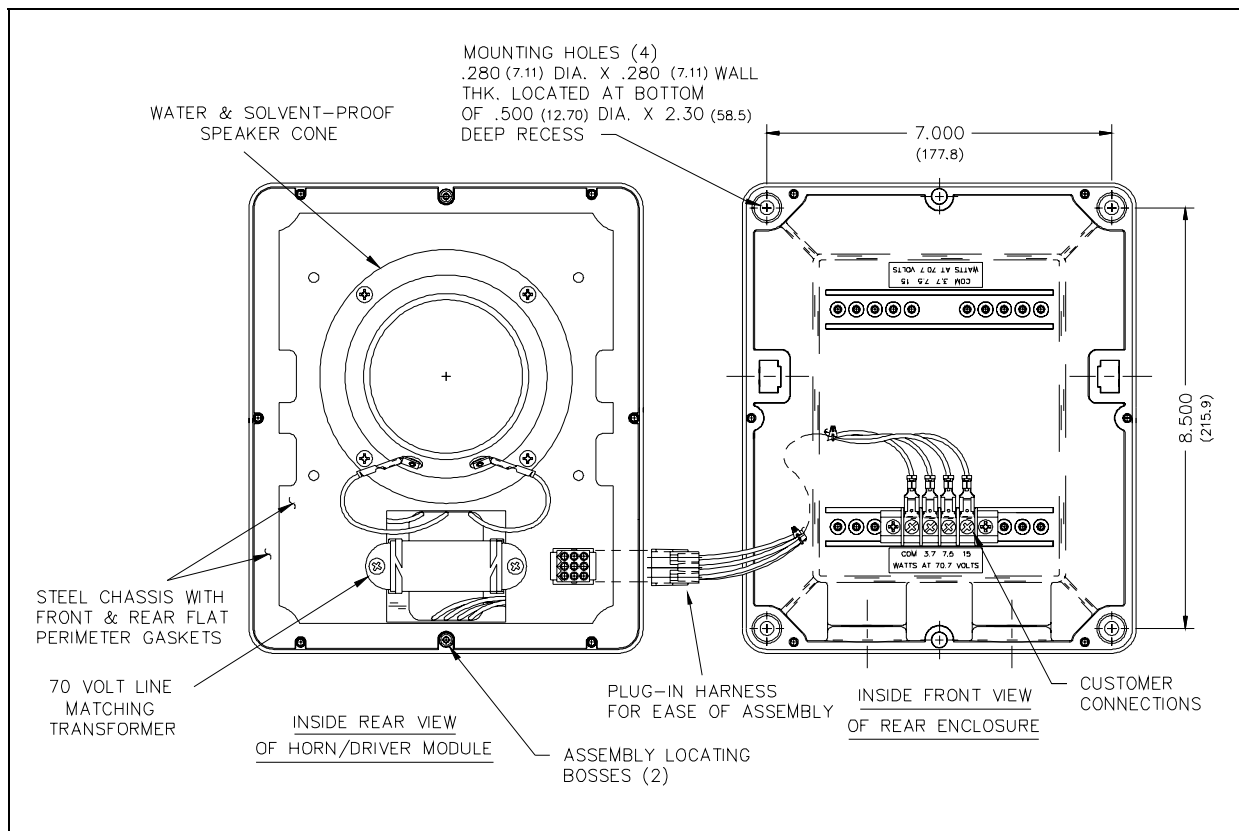

Figure 3. Model 13351 Loudspeaker Wiring

The rear enclosure is completely reversible with the front assembly, allowing the conduit entries to be positioned at the top or bottom of the speaker. Mounting holes are integral to the rear enclosure, and will not affect the watertight integrity of the enclosure.

NOTE: If conduit entries are positioned at the top of the enclosure, and hollow 3/4-inch conduit is used, entries to the enclosure should be internally plugged using a suitable sealant to avoid condensation within the enclosure.

Alternate Mounting Options

For unique mounting applications, please contact your GAI-Tronics sales consultant.

Specifications

Mechanical

Enclosure..... Glass-reinforced polyester, 0.20 inch thick

Hardware..... Urethane gaskets, stainless steel hardware

Electrical

RMS power rating..... 16 watts

Sensitivity..... 107 dB, 1 watt at 1 meter

Nominal coverage when surface-mounted to wall (ref. -6 dB)

Vertical..... Upward: 40 degrees
Downward: 60 degrees

Horizontal..... 90 degrees

Replacement Parts

Part Number	Description
12533-001	Speaker Replacement Kit
12532-001	Transformer Replacement Kit
12531-001	Wire Harness Replacement Kit

Warranty

Equipment. GAI-Tronics warrants for a period of one (1) year from the date of shipment, that any GAI-Tronics equipment supplied hereunder shall be free of defects in material and workmanship, shall comply with the then-current product specifications and product literature, and if applicable, shall be fit for the purpose specified in the agreed-upon quotation or proposal document. If (a) Seller's goods prove to be defective in workmanship and/or material under normal and proper usage, or unfit for the purpose specified and agreed upon, and (b) Buyer's claim is made within the warranty period set forth above, Buyer may return such goods to GAI-Tronics' nearest depot repair facility, freight prepaid, at which time they will be repaired or replaced, at Seller's option, without charge to Buyer. Repair or replacement shall be Buyer's sole and exclusive remedy. The warranty period on any repaired or replacement equipment shall be the greater of the ninety (90) day repair warranty or one (1) year from the date the original equipment was shipped. In no event shall GAI-Tronics warranty obligations with respect to equipment exceed 100% of the total cost of the equipment supplied hereunder. Buyer may also be entitled to the manufacturer's warranty on any third-party goods supplied by GAI-Tronics hereunder. The applicability of any such third-party warranty will be determined by GAI-Tronics.

Services. Any services GAI-Tronics provides hereunder, whether directly or through subcontractors, shall be performed in accordance with the standard of care with which such services are normally provided in the industry. If the services fail to meet the applicable industry standard, GAI-Tronics will re-perform such services at no cost to buyer to correct said deficiency to Company's satisfaction provided any and all issues are identified prior to the demobilization of the Contractor's personnel from the work site. Re-performance of services shall be Buyer's sole and exclusive remedy, and in no event shall GAI-Tronics warranty obligations with respect to services exceed 100% of the total cost of the services provided hereunder.

Warranty Periods. Every claim by Buyer alleging a defect in the goods and/or services provided hereunder shall be deemed waived unless such claim is made in writing within the applicable warranty periods as set forth above. Provided, however, that if the defect complained of is latent and not discoverable within the above warranty periods, every claim arising on account of such latent defect shall be deemed waived unless it is made in writing within a reasonable time after such latent defect is or should have been discovered by Buyer.

Limitations / Exclusions. The warranties herein shall not apply to, and GAI-Tronics shall not be responsible for, any damage to the goods or failure of the services supplied hereunder, to the extent caused by Buyer's neglect, failure to follow operational and maintenance procedures provided with the equipment, or the use of technicians not specifically authorized by GAI-Tronics to maintain or service the equipment. **THE WARRANTIES AND REMEDIES CONTAINED HEREIN ARE IN LIEU OF AND EXCLUDE ALL OTHER WARRANTIES AND REMEDIES, WHETHER EXPRESS OR IMPLIED BY OPERATION OF LAW OR OTHERWISE, INCLUDING ANY WARRANTIES OF MERCHANTABILITY OR FITNESS FOR A PARTICULAR PURPOSE.**

Return Policy

If the equipment requires service, contact your Regional Service Center for a return authorization number (RA#). Equipment should be shipped prepaid to GAI-Tronics with a return authorization number and a purchase order number. If the equipment is under warranty, repairs or a replacement will be made in accordance with the warranty policy set forth above. Please include a written explanation of all defects to assist our technicians in their troubleshooting efforts.

Call 800-492-1212 (inside the USA) or 610-777-1374 (outside the USA) for help identifying the Regional Service Center closest to you.