



GAI-TRONICS® CORPORATION
A HUBBELL COMPANY

Model ITR1000-001 Basic Tone Remote Desk Set with Line Select User and Installation Manual



CONFIDENTIALITY NOTICE

This manual is provided solely as an operational, installation, and maintenance guide and contains sensitive business and technical information that is confidential and proprietary to GAI-Tronics. GAI-Tronics retains all intellectual property and other rights in or to the information contained herein, and such information may only be used in connection with the operation of your GAI-Tronics product or system. This manual may not be disclosed in any form, in whole or in part, directly or indirectly, to any third party.

COMPUTER SOFTWARE COPYRIGHTS

This product contains copyrighted computer programs stored in semiconductor memory. These programs are copyrighted by GAI-Tronics Corporation and may not be reproduced in any form without express written permission from GAI-Tronics.

WARRANTY

GAI-Tronics warrants for a period of one (1) year from the date of shipment, that any GAI-Tronics equipment supplied hereunder shall be free of defects in material and workmanship, shall comply with the then-current product specifications and product literature, and if applicable, shall be fit for the purpose specified in the agreed-upon quotation or proposal document. If (a) Seller's goods prove to be defective in workmanship and/or material under normal and proper usage, or unfit for the purpose specified and agreed upon, and (b) Buyer's claim is made within the warranty period set forth above, Buyer may return such goods to GAI-Tronics' nearest depot repair facility, freight prepaid, at which time they will be repaired or replaced, at Seller's option, without charge to Buyer. Repair or replacement shall be Buyer's sole and exclusive remedy, and the warranty period on any repaired or replacement equipment shall be one (1) year from the date the original equipment was shipped. In no event shall GAI-Tronics' warranty obligations with respect to equipment exceed 100% of the total cost of the equipment supplied hereunder. The applicability of any such third-party warranty will be determined solely by GAI-Tronics.

Services. Any services GAI-Tronics provides hereunder, whether directly or through subcontractors, shall be performed in accordance with the standard of care with which such services are normally provided in the industry. If the services fail to meet the applicable industry standard, GAI-Tronics will, for a period of one (1) year from the date of completion, re-perform such services at no cost to the Buyer. Re-performance of services shall be Buyer's sole and exclusive remedy, and in no event shall GAI-Tronics' warranty obligations with respect to services exceed 100% of the total cost of services provided hereunder.

Limitations/Exclusions. The warranty on any equipment supplied hereunder is subject to Customer's use in compliance with applicable FCC regulations and manufacturer specifications. The warranties herein shall not apply to, and GAI-Tronics shall not be responsible for, any damage to the goods or failure of the services supplied hereunder, to the extent caused by accident, misuse, abuse, neglect, system design, product modification, failure to follow instructions contained in the product manual, repair, or attempted repair by anyone not authorized by GAI-Tronics, improper installation, installation of parts that do not conform to the quality or specifications of the original parts or accessories, damage or loss occurred during shipment, or any unit which is not new when sold or upon which the serial number has been defaced, modified or removed. The warranty does not extend to damage incurred by natural causes including Force Majeure. The warranty does not cover microprocessors if failure is due to static damage or application of improper voltage. **THE WARRANTIES AND REMEDIES CONTAINED HEREIN ARE IN LIEU OF AND EXCLUDE ALL OTHER WARRANTIES AND REMEDIES, WHETHER EXPRESS OR IMPLIED BY OPERATION OF LAW OR OTHERWISE, INCLUDING ANY WARRANTIES OF MERCHANTABILITY OR FITNESS FOR A PARTICULAR PURPOSE.**

Operational and Maintenance Procedures. Buyer acknowledges that any improper use, maintenance, or modification of the equipment provided hereunder, or use of unqualified maintenance or service technicians will severely impair the operational effectiveness of the entire communication system. Buyer hereby agrees to indemnify, defend and hold GAI-Tronics harmless from and against any and all third party claims arising, in any manner, out of: (a) Buyer's neglect of the equipment; (b) Buyer's use of technicians not authorized by GAI-Tronics to service the equipment; or (c) Buyer's improper use or modification of the equipment or failure to follow the operational and maintenance procedures provided with the equipment.

Limitation of Liability/Damages. In no event (even should circumstances cause the exclusive warranties and remedies set forth in the Warranty section to fail of their essential purpose) shall either party be liable for any indirect, incidental, special or consequential damages (including, but not limited to, loss of use, loss of anticipated profits, or damages arising from delay) whether such claims are alleged to have arisen out of breach of warranty, breach of contract, strict or absolute liability in tort, or other act, error or omission, or from any other cause whatsoever, or any combination of the foregoing.

Table of Contents

FOREWORD	1
SCOPE OF MANUAL.....	1
NOMENCLATURE.....	1
ORDERING REPLACEMENT PARTS.....	1
SERVICE AND REPAIR	1
FCC INTERFERENCE WARNING.....	1
SAFE HANDLING OF CMOS INTEGRATED CIRCUIT DEVICES	2
DESCRIPTION.....	3
FEATURES AND BENEFITS OF THE ITR1000-001 BASIC TONE REMOTE DESK SET	3
PHYSICAL DESCRIPTION	4
DESK SET BUTTON PANEL	4
<i>F1, F2, F3, and F4/LS Frequency Buttons</i>	5
<i>Volume Buttons</i>	5
<i>Control Button</i>	5
<i>Intercom Button</i>	5
<i>Monitor Button</i>	5
<i>Transmit Button</i>	5
<i>Transmit LED</i>	5
INTERNAL MICROPHONE.....	5
HANDSET.....	5
PROGRAMMING SWITCHES.....	6
<i>SWA Switch Settings Table</i>	6
LINE SELECT (F4/LS).....	6
ITR1000-001 BASIC TONE REMOTE DESK SET ACCESSORIES	7
ITR1000-001 BASIC TONE REMOTE DESK SET FIELD REPLACEMENT ITEMS.....	7
PERFORMANCE SPECIFICATIONS.....	8
OPERATION	9
OPERATIONAL DESCRIPTION	9
FRONT PANEL BUTTON OPERATION	9
<i>F1, F2, and F3 Frequency Buttons</i>	9
<i>F4/LS Button</i>	9
<i>VOLUME Up/Down Buttons</i>	9
<i>CONTROL Button</i>	9
<i>IC (Intercom) Button</i>	9
<i>MONITOR Button</i>	10
<i>TRANSMIT Button</i>	10
INITIATING CALLS	10
RECEIVING CALLS	10
HANDSET TRANSMIT	10
TRANSMIT FROM INTERNAL MICROPHONE	10
INSTALLATION	11
PLANNING THE INSTALLATION	11
MECHANICAL RECEIPT INSPECTION.....	11
MOUNTING	11
FCC INTERFERENCE WARNINGS	11
EQUIPMENT REQUIRED	12

CABLE INSTALLATION SAFETY CONSIDERATIONS	12
TELEPHONE LINE LIGHTNING AND OVER-VOLTAGE PROTECTION.....	12
POWER CONNECTIONS.....	12
LINE CONNECTIONS	13
<i>Line Considerations - Private Circuit</i>	13
<i>Circuit Conditioning</i>	13
SETTINGS AND ADJUSTMENTS.....	14
<i>Line (Receive Audio) Input Level Adjustment</i>	14
<i>Line Output (Transmit) Level Adjustment</i>	14
<i>Audio Level Setting Procedure</i>	15
<i>2175 Hz Filter Adjustment</i>	16
<i>Handset Microphone Adjustment</i>	16
DESK SET REASSEMBLY.....	16
PROGRAMMING	17
<i>High Level Guard Tone Durations</i>	18
<i>Function Tone Durations</i>	18
<i>Function Tone Frequencies</i>	19
PROGRAMMING MODE.....	20
THEORY OF OPERATION	21
DIGITAL CIRCUITS.....	21
<i>Analog-to-Digital Conversions</i>	21
<i>Serial Peripheral Interface</i>	21
AUDIO CIRCUITS	21
SPEAKER VOLUME CONTROL	22
POWER SUPPLIES.....	22
LINE SELECT.....	22
TROUBLESHOOTING.....	23
TROUBLESHOOTING THE ITR1000-001 BASIC TONE REMOTE DESK SET	23
FUSE REPLACEMENT.....	24
MAIN CIRCUIT BOARD.....	25
SCHEMATICS.....	27
DEFINITIONS AND ACRONYMS.....	35

Scope of Manual

This manual offers descriptive data and service information for the Model ITR1000-001 Basic Tone Remote Desk Set. Service diagrams and printed circuit board details are a part of this service manual.

Nomenclature

The model number, located on the nameplate on the bottom, specifically identifies GAI-Tronics equipment. If additional options are ordered, the option will be identified on the circuit board.

Ordering Replacement Parts

When ordering replacement parts or requesting equipment information, please include the complete identification number. This applies to all components, kits, and chassis. If the component part number is not known, the order should include the number of the chassis or kit of which it is a part and sufficient description of the desired component to identify it. Order parts from:

Customer Service

GAI-Tronics Corporation

400 E. Wyomissing Ave.

Mohnton, PA 19540

US: 800-492-1212

Outside US: 610-777-1374

Service and Repair

Inoperative or malfunctioning equipment should be returned to the factory for repair. Please call **1-800-492-1212** to obtain a Return Authorization number, published repair prices, and shipping instructions.

NOTE: A purchase order or credit card number is required prior to processing non-warranty repairs.

FCC Interference Warning

The FCC requires that manuals pertaining to Class A and Class B computing devices must contain warnings about possible interference with local residential radio and TV reception. This warning reads as follows:

NOTE: This equipment has been tested and found to comply with the limits for a Class A digital device, pursuant to Part 15 of the FCC Rules. These limits are designed to provide reasonable protection against harmful interference when the equipment is operated in a commercial environment. This equipment generates, uses, and can radiate radio frequency energy and, if not installed and used in accordance with the instruction manual, may cause harmful interference to radio communications. Operation of this equipment in a residential area is likely to cause harmful interference in which case the user will be required to correct the interference at his own expense.

Safe Handling of CMOS Integrated Circuit Devices

Many of the integrated circuit devices used in communications equipment are of the Complementary Metal Oxide Semiconductor (CMOS) type. Because of their high open circuit impedance, CMOS integrated circuits are vulnerable to damage from static charges. Care must be taken handling, shipping, and servicing them and the assemblies in which they are used.

Even though protection devices are provided in CMOS integrated circuit inputs, the protection is effective only against over-voltage in the hundreds of volts range such as is encountered in an operating system. In a system, circuit elements distribute static charges and load the CMOS circuits, decreasing the chance of damage. However, CMOS circuits can be damaged by improper handling of the modules, even in a system.

To avoid damage to circuits, observe the following handling, shipping, and servicing precautions:

1. Prior to and while servicing a circuit module, particularly after moving within the service area, momentarily touch both hands to a bare metal, earth-grounded surface. This will discharge any static charge that may have accumulated on the person doing the servicing.
NOTE: Wearing a conductive wrist strap will minimize static build-up during servicing.
2. Whenever possible, avoid touching any electrically conductive parts of the circuit module with your hands.
3. Power down the unit before installing or removing the circuit module.
4. When servicing a circuit module, avoid carpeted areas, dry environments, and certain types of clothing (silk, nylon, etc.) because they contribute to static build-up. Similarly, disconnect the test probe prior to removing the ground lead.
5. All electrically powered test equipment should be grounded. Apply the ground lead from the test equipment to the circuit module before connecting the test probe.
6. If a circuit module is removed from the system, it is desirable to lay it on a conductive surface (such as a sheet of aluminum foil) which is connected to ground through 100k of resistance.
7. When soldering, be sure the soldering iron is grounded and has a grounded tip.
8. Prior to connecting jumpers, replacing circuit components, or touching CMOS pins (if this becomes necessary in the replacement of an integrated circuit device), be sure to discharge any static build-up as described in procedure 1. Since voltage differences can exist across the human body, it is recommended that only one hand be used if it is necessary to touch pins on the CMOS device and associated board wiring.
9. When replacing a CMOS integrated circuit device, leave the device in its conductive rail container or conductive foam until it is to be inserted into the printed circuit module.
10. All low impedance test equipment (such as pulse generators, etc.) should be connected to CMOS device inputs after power is applied to the CMOS circuitry. Similarly, such low impedance equipment should be disconnected before power is turned off.
11. Replacement modules shipped separately from the factory will be packaged in a conductive material. Any modules being transported from one area to another should be wrapped in a similar material (aluminum foil may be used). **Never use non-conductive material** for packaging these modules.

 Features and Benefits of the ITR1000-001 Basic Tone Remote Desk Set

Feature	Benefit
Adjustable receive input sensitivity and transmit output level	Allows flexibility with different radio systems and user environments where radio output levels, line losses, and noise factors vary.
Line receive and transmit compression	Automatically normalizes varying input and output levels caused by system factors.
Built-in internal microphone and speaker	Allows for hands-free communication.
Intercom capability	Desk set users can communicate with each other without tying up valuable radio channels.
Selectable off-hook local speaker	User can choose continuous local speaker when handset is off-hook.
Programmable 3- or 4-frequency function control	Any one of 16 EIA standard tones can be programmed for each frequency/function key. (4-frequency control during basic operation; 3-frequency control during Line Select operation.)
Parallel transmit audio	User can hear audio transmitted by another desk set.
Line Select	Allows selection between two separate radio channels for TX/RX control of the three frequencies. Line Select operation is selectable via DIP switch. NOTE: The unit will monitor RX audio of the selected channel only.
Continuous monitoring	Enables received audio to be broadcast over the integral speaker when the handset is off-hook. This feature is selectable via DIP switch.

Physical Description

The Model ITR1000-001 Basic Tone Remote Desk Set, when used with a tone remote adapter such as the ITA2000, provides options for remote control of base station radios. It can be used as a desk set or mounted vertically on a wall. All connections are made inside the unit. Power is supplied by an ac wall transformer that is provided with the desk set.

Desk Set Button Panel

Refer to the figure below for the locations of the buttons and LED on the desk set button panel.

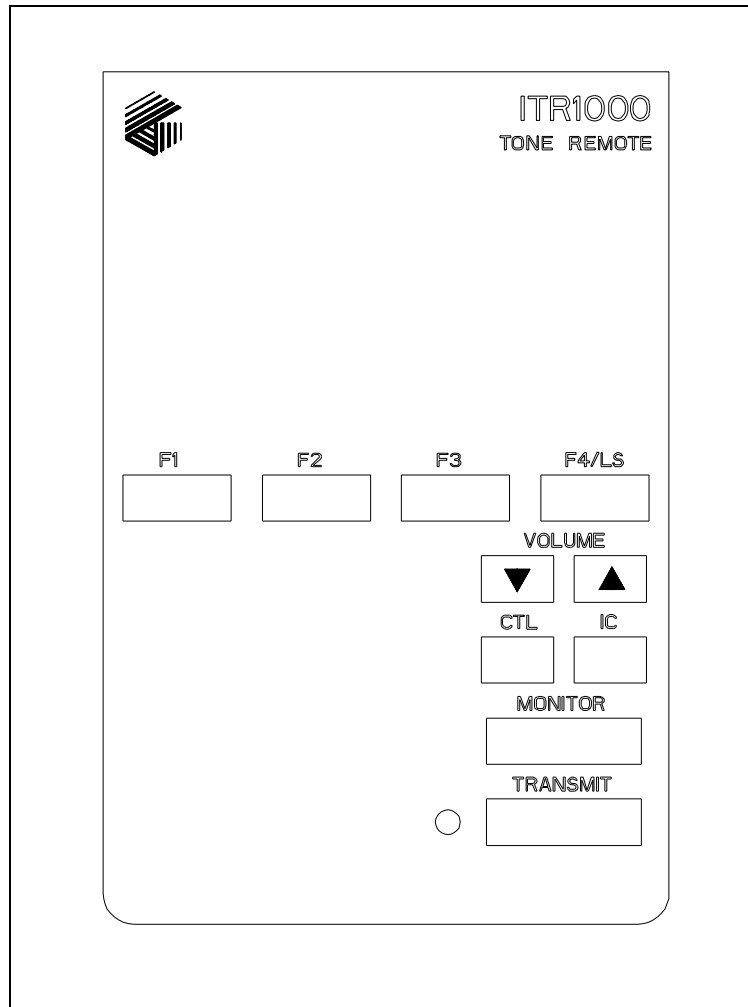

Front View of the ITR1000-001 Desk Set Button Panel

F1, F2, F3, and F4/LS Frequency Buttons

Normally, these buttons are used to change frequencies on the selected radio. However, the use and function of these buttons are dependent on your radio's capabilities. Whenever a frequency button is pressed, the button illuminates until a different frequency button is pressed. The F4/LS button and LED are used to select the desired line (radio channel), if programmed to do so.

Volume Buttons

The desk set includes two buttons labeled VOLUME. One is imprinted with an up arrow, and the other with a down arrow. They are used to increase and decrease the local speaker volume and as programming function keys.

Control Button

The CTL button is used in conjunction with the VOLUME Up or VOLUME Down buttons to control the local speaker. It is also used during programming.

Intercom Button

The Intercom button, labeled IC, allows communication between desk set users without transmission over the radio.

Monitor Button

The MONITOR button is used to place the radio in the monitor mode.

Transmit Button

The TRANSMIT button is used to initiate voice transmissions. Pressing the TRANSMIT button places the desk set in the transmit mode.

Transmit LED

The TRANSMIT LED illuminates when transmitting.

Internal Microphone

This microphone is intended for use in low noise environments. The handset must be on-hook in order to use the microphone.

Handset

The desk set is equipped with a handset with a coil cord used for receiving and transmitting calls. The handset includes a push-to-talk (PTT) pressbar.

Programming Switches

A set of programming switches is included on the desk set. The switch settings are as follows:

SWA Switch Settings Table

Switch	Determines:	On	Off (Default)
SWA-1	Whether the handset off-hook monitor is enabled or disabled	Enabled	Disabled
SWA-2	The frequency change commands	Pressing the frequency button does not immediately change the station frequency. It changes only after TX or handset PTT is pressed.	Pressing the frequency button immediately changes the station frequency.
SWA-3	2-Line Operation	Enabled	Disabled
SWA-4	Operation with handset removed	Allows the use of the internal mic and local speaker without handset.	Handset must be present for proper operation.
SWA-5	Continuous live speaker	Enabled	Disabled
SWA-6	Whether line termination is enabled or disabled	Disabled	Enabled
SWA-7	Guard tone keying	Special application: No function tones are generated when TX or handset PTT is pressed.	Normal Operation: Function tones are generated prior to LLGT.
SWA-8	Access to front panel programming mode is enabled or disabled	Disabled	Enabled

NOTE: The factory default for all SWA switches is off. Power to the unit must be cycled off and on in order for the new setting to take effect.

Line Select (F4/LS)

The ITR1000-001 allows input of two distinct radio line wire pairs. The desired line pair for transmission and/or reception is selected by means of the front panel button labeled F4/LS. This feature is enabled via DIP switch position SWA-3.

NOTE: The ITR1000-001 Desk Set will monitor the receive audio of the selected line (L1 or L2) only.

ITR1000-001 Basic Tone Remote Desk Set Accessories

Description	Part No.
Tone Remote Adapter	ITA2000A
Audio Accessory Box	XAAB002A
Desk Microphone*	XDM002A
Footswitch*	XFS002A
Headset* (requires coiled cord)	XHS003B
Headset Coiled Cord*	XCC004B

*These accessories require the use of the XAAB002A Audio Accessory Box.

ITR1000-001 Basic Tone Remote Desk Set Field Replacement Items

Description	Part No.
Handset with Cord, Black	HANDSET - BLACK
Replacement Power Supply	3308-50008-00
Speaker Assembly	61501-014
Replacement PCBA	69306-101

Performance Specifications

Color	Black
Physical size	7.6 W × 8.9 L × 4.7 H inches
Weight	2.4 lbs.
Temperature range	-35° C to +70° C
Humidity	95% at 50° C (non-condensing)
Line impedance	600 ohms nominal
Power input	10.5–16 V dc; 0.5 A maximum from Class 2 listed ac adapter
Nominal input level	-10 dBm Range -25 to 0 dBm into 560 ohms
Nominal output level	-10 dBm Range -15 to +15 dBm into 560 ohms
Frequency response	±3 dB, 300-3000 Hz (except notch filter)
Frequency stability	Better than ±1.0%
Hum and noise	Less than -45 dB below rated outputs
Audio output to speakers	1 watt minimum with level in compression range
Audio distortion	Less than 3% THD
Maximum number of remotes	10
Control functions	
Guard tone	2175 Hz
F1	1950 Hz
F2	1850 Hz
F3	1750 Hz
F4 (used only in basic operation)	1650 Hz (F1 through F4 can be programmed from 550 to 2050 Hz in 100 Hz increments)
Monitor	2050 Hz (Monitor control function can not be programmed.)
Safety	Class III SELV-powered equipment. Powered by UL-listed (E104603) and CSA certified (LR67888) ac adapter
Emissions	USA: FCC Part 15, Sub. B-Verification Canada: ICES-003
Line interface	USA: FCC Part 68 Exempt (Category II Tariff #260 service for private/leased line applications) Canada: Designed to meet IC CS03-8 (Certification pending)

Operational Description

The ITR1000-001 Basic Tone Remote Desk Set provides radio system control from a remote location. The desk set control tones are sent to the tone remote adapter through a private or leased line, and are used to control radio functions such as transmit, channel changes, and monitor. The receive audio from the radio system is sent to the desk set from the radio via the same private or leased line.

The F1, F2, and F3 buttons allow the selection of three different base station frequencies depending upon the capabilities of your radio and the tone remote adapter. The desk set is compatible with tone remote adapters that accept standard EIA tone keying sequences.

Front Panel Button Operation

F1, F2, and F3 Frequency Buttons

The frequency buttons are normally used to change channels on the radio. The actual use and function of these buttons may be different depending upon your radio's capabilities. Whenever a frequency button is pressed, the button illuminates until a different frequency button is pressed.

F4/LS Button

In basic operation, the F4/LS button provides control of a fourth frequency. In Line Select operation, the F4/LS button functions as the "line select" button. Pressing the button toggles selection between line 1 and line 2. If the button is illuminated, line 2 is selected; if extinguished, line 1 is selected. This function must be enabled by moving SWA-3 to the ON position.

VOLUME Up/Down Buttons

Press the VOLUME Up or VOLUME Down buttons to adjust the local speaker volume. They are also used as programming function keys.

CONTROL Button

The CTL button is used in conjunction with the VOLUME Up and Down buttons to manually control the local speaker. Press and hold the CTL button, and then press the VOLUME Up or VOLUME Down button.

Pressing the CTL and the VOLUME Down buttons mutes the local speaker, and the selected frequency button flashes to alert the user that the speaker is muted. The speaker can be unmuted by pressing the VOLUME Up, VOLUME Down, or CTL and VOLUME Up buttons.

Pressing the CTL and the VOLUME Up buttons enables the local speaker while the handset is off-hook. When the handset is placed back on-hook, the local speaker again operates normally— that is, it will be disabled whenever the handset is taken off-hook.

IC (Intercom) Button

Press the IC button to communicate between desk sets without transmitting over the radio. When the IC button is pressed and held, microphone audio is routed to the line without activating the radio transmitter. Other tone remote desk sets on the same line will hear the audio automatically.

MONITOR Button

Press the MONITOR button (CTCSS/CDCSS disable) to place the radio in the monitor mode. Press this button before making a call to verify a clear radio channel is available.

TRANSMIT Button

Press the TRANSMIT button to place the desk set in the transmit mode and initiate voice transmissions.

Initiating Calls

Before initiating a call, press the MONITOR button to verify that the radio channel is clear. To initiate a call, press the TRANSMIT button or the handset push-to-talk (PTT) pressbar. The TRANSMIT LED illuminates when transmitting.

Always allow a short delay before speaking to allow time for the radio channel to be established. The TRANSMIT button or handset PTT bar must be held down while talking to the radio user and released to listen. When the transmission is completed, the TRANSMIT LED extinguishes and the desk set returns to the receive mode.

Receiving Calls

When power is applied, the desk set is in the receive mode, allowing receive audio to be heard through the speaker or handset. The desk set is always in receive mode unless the user presses the TRANSMIT or IC buttons.

The desk set contains an internal or local speaker and a handset speaker, which operate as follows:

- When the handset is in the cradle or on-hook, receive audio is heard on the local internal speaker.
- When the handset is off-hook, receive audio is routed to the handset.

Handset Transmit

Using the handset is recommended when the desk set is located in noisy surroundings. Press the handset PTT bar or TRANSMIT button and speak into the handset microphone.

Transmit From Internal Microphone

Use the internal microphone only in low noise environments. The handset must be on-hook for the internal microphone to operate. Press the TRANSMIT button and speak in the direction of the internal microphone. For the best transmit audio quality, maintain a distance of about 12 to 18 inches from the microphone.

Planning the Installation

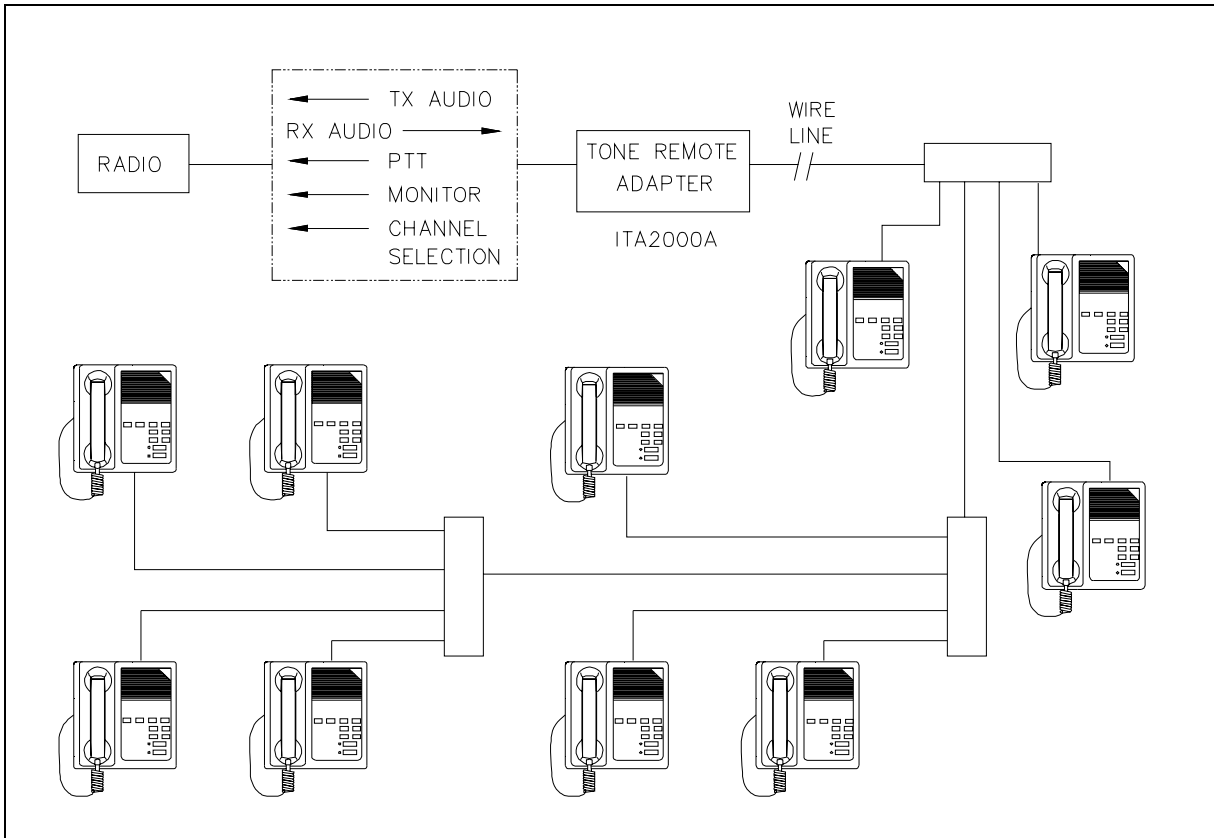

Sample ITR1000-001 Installation Diagram - Shown connected in parallel within one building.

Mechanical Receipt Inspection

The ITR1000-001 Basic Tone Remote Desk Set is shipped in a cardboard container with inserts. Thoroughly inspect it as soon as possible after delivery. In-transit damage should be immediately reported to the transportation company.

Mounting

The desk set can be placed on a desk or mounted vertically on a wall. To wall mount the desk set, remove the four bottom screws from the base and then rotate the base 180°. Reinstall the four screws to the base and rotate the handset hook located on the front of the unit.

FCC Interference Warnings

The FCC requires that manuals pertaining to Class A and Class B computing devices contain warnings about possible interference with local and residential radio and TV reception. Please read these warnings and all safety information in the Foreword section of this manual.

Equipment Required

Test Equipment

- RF service monitor
- AC voltmeter with dB ranges for measuring audio levels
- #1 Phillips screwdriver
- 1/8-inch flat blade screwdriver

Documentation

- base station's tone remote adapter manual
- these installation instructions

Cable Installation Safety Considerations

Interconnecting, communications, and Class 2 dc power cables should be separated from electrical light or other Class I circuits by at least 2 inches. The exception is where Class I wiring or power circuits are run in a raceway, or are metal-sheathed or metal-clad, or are permanently separated from the conductors of the other circuitry by a continuous and firmly fixed nonconductor such as porcelain tubes or flexible tubing in addition to the insulation on the wire. Communications cables and in-building wiring should be listed and marked for the purpose according to NEC Article 800.

Telephone Line Lightning and Over-voltage Protection

The ITR1000-001 Basic Tone Remote Desk Set has an over-current phone line fuse (F2) which protects against occasional extreme fault conditions that may get past the primary protectors. An example of such a fault condition is a power line cross. If the fuse requires replacement, replace F2 only with the same type Bussmann C515S 1.25A fuse.

For maximum surge and lightning protection, building primary (over-voltage) protectors should be installed at the point where the telephone lines enter the radio equipment building. Primary protectors are usually required by local codes and should be provided by your leased line provider.

Power Connections

Power is applied to the ITR1000-001 from the provided ac wall transformer that is supplied with the unit. Power is applied to TS1-6(+) and TS1-5(-).

Line Connections

To make the required line connections, a cable with a tinned bare leads stripped to about 3/8-inch or pin terminal is necessary. With the housing opened, route the lines through the slot in the housing bottom. Using a small slotted screwdriver, connect the Line 1 two-wire line to the TS1 terminal block on the main circuit board at terminal positions 3 and 4. Connect the Line 2 two-wire line to the TS1 terminal block at positions 1 and 2.

Several desk sets can be connected in parallel. The maximum loss between any two desk sets, or between a desk set and the station, should not exceed 20 dB. Desk sets are shipped with line termination enabled. With parallel units connected, only the farthest desk set unit should be terminated. Setting SWA-6 to off enables line termination; setting SWA-6 to on disables line termination. Refer to SWA Switch Settings Table in the Description section of this manual.

Line Considerations - Private Circuit

If leased lines from your local telephone company are used between the desk sets and the ITA2000 or similar tone remote adapter, the telephone company (Local Exchange Carrier) may request a Facility Interface Code (FIC). The FIC is subject to local availability.

Analog Facility Interface Code

FIC	Description
02NO2	2-wire private line; no signaling conversion by LEC (IN-Band)

Within a manufacturing plant, a campus, or large building, customer-supplied metallic pairs may be used. It is not necessary to have dc continuity on these lines.

Circuit Conditioning

The desk set is designed to work with good-quality analog speech band or leased private circuit. This was previously known as 'basic' conditioning under Series 2000/3002 service. The line must be non-PSTN (no dial tone, talk-battery, or signaling).

This equipment falls under the Category II, FCC Tariff #260 Service and is exempt from FCC Part 68 registration. (Ref. FCC Form 730 Application Guide pages 1-5.)

For 2-wire operation, 2000 Series lines may be used with or without conditioning. C1 or C2 conditioning is available for these lines and relates to the envelope delay distortion and attenuation. A basic conditioned line may be used if it is the only type available. Overall system quality is limited by the quality of these lines.

Settings and Adjustments

The desk set housing must be open with the circuit board exposed. These procedures assume that the base station has been properly adjusted.

Line (Receive Audio) Input Level Adjustment

This ensures that the tone remote desk set compression amplifier circuitry operates properly on signals from the base station.

1. Adjust the base station level by applying an RF signal modulated with a 1000 Hz tone at rated system deviation to the base station receiver.
2. Adjust the base station output control for the desired level (e.g. -10 dBm) to the audio control line. Do not exceed the line supplier's recommended maximum operating level.

Remote Adjustment:

1. Connect an ac voltmeter to TPC1 on the main circuit board.
2. Starting with the line input control (pot 3) rotated fully clockwise, adjust the line input control until the ac voltage level across the meter just stops increasing at approximately -2 dBm.
3. Remove the RF signal from the base station.

Line Output (Transmit) Level Adjustment

This process ensures the correct audio signal level is output to the remote control line during transmission.

1. Disconnect the handset from the desk set.
2. Apply a 1000 Hz at 44 mV ac signal into the handset mic terminals (red = handset mic; black = ground).
3. Press the TRANSMIT button and adjust the line output level control (pot 4) on the main circuit board until the desired output is obtained (e.g. -10 dBm) to the remote control line. Do not exceed the line supplier's recommended maximum level.
4. Remove the signal from the handset mic terminals and reconnect the handset.

Audio Level Setting Procedure

1. Set up an RF signal generator on the receive frequency with a 1 kHz tone set to system reference modulation applied to the station antenna.
2. Apply sufficient RF level to ensure a fully quieted radio channel, typically 1000 microvolts. If used, enable the correct receive CTCSS/CDCSS code.
3. Measure and note the level of the 1 kHz tone impressed on the radio tie line. Adjust the station's tone remote adapter to produce the desired line level, e.g. -10 dBm.
4. With the 1 kHz tone still applied from the station receiver, monitor the remote audio with an ac voltmeter at test point TPC1.
5. Slowly adjust the desk set receive level potentiometer (pot 3) until the level just stops increasing (knee of compression) at approximately -2 dBm.
6. If multiple desk sets are used, repeat this procedure for each unit. Ensure that only the most distant desk set from the station receiver has the RX line termination jumper in place. Refer to the Switch Settings Table in the Description section of this manual.
7. If an RF generator is not available, the RX level pots can be adjusted while monitoring a mobile radio transmission. Adjust the pot as described above until the level at the test point just stops increasing at approximately -2 dBm. This can be done during a continuous speech transmission, or during a test conducted from the mobile radio. A setting that is too high may result in excessive background noise, or 'pumping' of audio.

2175 Hz Filter Adjustment

This setting is factory adjusted and should only need readjustment if the notch filter circuitry needs repairs. Perform the following steps to make adjustments:

1. Cycle power to the desk set.
2. While all LEDs are illuminated, press the CTL and the F1 buttons to enter the F1 frequency programming mode.
3. Press the CTL and IC buttons to cause the desk set to generate a 2175 Hz tone. This tone should be audible through the speaker.
4. Adjust pot 1 until the tone in the speaker is at minimum volume.

Handset Microphone Adjustment

This adjustment is factory-set at a nominal level suitable for many applications. Make adjustments only after the receive audio level pot and SWA-8 have been properly set.

1. Locate the handset earpiece volume control, which is accessible through the lower slotted mounting hole (pot 5) without opening the unit.
2. If adjustment is needed, use a 1/8-inch slotted screwdriver to adjust pot 5 to a comfortable volume level.
3. Press the TRANSMIT button to return to normal operation.

Desk Set Reassembly

After making the required connections, replace the top cover on the desk set and reattach the four screws in the corners of the back housing.

Programming

Front panel programming and the diagnostic mode are accessed by keypress combinations entered within 3 seconds of power up. During this period, all of the LEDs illuminate as an indication that programming changes can be made.

Access to the programming and diagnostic functions can be disabled by SWA-8. This allows the installing technician to set parameters and then disable access to programming functions. When disabled, users cannot accidentally change parameters.

F1 through F4 function tones are set at the factory to the following frequencies:

F1 = 1950 Hz

F2 = 1850 Hz

F3 = 1750 Hz

F4 = 1650 Hz

To adjust and program the tone durations and frequencies, see the Programming Mode Chart on page 20. Frequency adjustments are made in 100 Hz increments. The tables below show the conditions of the LEDs in the respective FREQUENCY button.

For example, for a HLG T Duration of 300 ms:

F1 button LED is Off; the F2 LED is Off; the F3 LED is On; and the F4 LED is Off.

High Level Guard Tone Durations

F1	F2	F3	F4	Duration
Off	Off	Off	Off	120 ms
Off	Off	Off	On	200 ms
Off	Off	On	Off	300 ms
Off	Off	On	On	400 ms
Off	On	Off	Off	500 ms

Function Tone Durations

F1	F2	F3	F4	Duration
Off	Off	Off	Off	40 ms
Off	Off	Off	On	50 ms
Off	Off	On	Off	60 ms
Off	Off	On	On	70 ms
Off	On	Off	Off	80 ms

Function Tone Frequencies

F1	F2	F3	F4	Duration
Off	Off	Off	Off	2050 Hz
Off	Off	Off	On	1950 Hz
Off	Off	On	Off	1850 Hz
Off	Off	On	On	1750 Hz
Off	On	Off	Off	1650 Hz
Off	On	Off	On	1550 Hz
Off	On	On	Off	1450 Hz
Off	On	On	On	1350 Hz
On	Off	Off	Off	1250 Hz
On	Off	Off	On	1150 Hz
On	Off	On	Off	1050 Hz
On	Off	On	On	950 Hz
On	On	Off	Off	850 Hz
On	On	Off	On	750 Hz
On	On	On	Off	650 Hz
On	On	On	On	550 Hz

While in the programming or diagnostic mode, the TRANSMIT LED flashes to indicate that the desk set is not in normal operation.

To exit a programming mode and return to normal operation, press the TRANSMIT button. Otherwise, the desk set automatically exits and returns to normal operation 5 minutes after a programming mode is entered.

Programming Mode

NOTE: The initial keypress must be made within 3 seconds of power up.

The desk set automatically exits the program mode and returns to normal operation after 5 minutes.

Programming Function	Keypress
Adjust and program HLG T duration. See High Level Guard Tone Duration Table for LED on/off configurations.	CTL + TRANSMIT (within 3 sec. of power up)
<ul style="list-style-type: none"> • Generate control tone burst. 	MONITOR
<ul style="list-style-type: none"> • Increase HLG T duration. 	VOLUME Up
<ul style="list-style-type: none"> • Decrease HLG T duration. 	VOLUME Down
Adjust and program function tone duration. See Function Tone Duration Table for LED on/off configurations.	CTL + MONITOR (within 3 sec. of power up)
<ul style="list-style-type: none"> • Generate control tone burst. 	MONITOR
<ul style="list-style-type: none"> • Increase function tone duration. 	VOLUME Up
<ul style="list-style-type: none"> • Decrease function tone duration. 	VOLUME Down
Adjust and program Function Tone Frequency. See Function Tone Frequency Table for LED on/off configuration. NOTE: A continuous function tone frequency selected for F1, F2, F3, or F4 is generated to the speaker and wire line during this adjustment.	CTL + F1, F2, F3, OR F4 (within 3 sec. of power up)
<ul style="list-style-type: none"> • Increase function tone frequency. 	VOLUME Up
<ul style="list-style-type: none"> • Decrease function tone frequency. 	VOLUME Down
<ul style="list-style-type: none"> • Enable FREQUENCY button. 	CTL + VOLUME Up
<ul style="list-style-type: none"> • Disable FREQUENCY button (F1 can not be disabled.) 	CTL + VOLUME Down
<ul style="list-style-type: none"> • Switch tone generation level (High Level, Function Tone Level, Low Level). 	IC
<ul style="list-style-type: none"> • Switch to generation of 2175 Hz to allow adjustment of notch filter pot. 	CTL + IC
<ul style="list-style-type: none"> • Switch back to generation of function tone frequency Reference number for the frequency (0-15) is indicated in binary form on the F1–F4 LEDs. When the frequency button is disabled, the LEDs flash the value. When enabled, they remain illuminated.	CTL + IC, or VOLUME Up, or VOLUME Down
RAM Diagnostic	CTL + IC (within 3 sec. of power up)
The RAM diagnostic runs, default parameters are reloaded and the unit resets. If the RAM diagnostic detects an error(s), the LEDs flash and the unit 'hangs' indefinitely. If the correct sequence is not entered within 15 seconds, the unit resets.	F3-F4-F2-F1 (within 15 sec.)

Digital Circuits

On power-up, microcontroller U1 reads switch SWA through tri-state buffer U3. Switch readings determine certain operating characteristics of the desk set.

Analog-to-Digital Conversions

Each keyboard button is associated with a particular voltage level at microcontroller inputs AN0 and AN1. These inputs are periodically scanned to determine whether a key is being pressed or released. The microcontroller determines whether the handset is on-hook, off-hook, or whether the handset PTT bar is being pressed by reading the voltage level at input AN2.

Serial Peripheral Interface

The microcontroller uses a synchronous serial interface to control LEDs, provide audio control logic, and to interface non-volatile memory U2. LEDs are turned on or off by the outputs of serial-to-parallel latch U6. The microcontroller manages audio circuits through the outputs of serial-to-parallel latch U4. Operating parameters such as function tone frequencies, etc., are stored in serial NVRAM U2.

Audio Circuits

Audio from the wire line is scaled through amplifier U12a and fed through the line audio adjustment, POT3. Then, it is high-pass filtered through U12b to remove wire line hum. The resulting signal is gated to the compressor circuit consisting of U11, Q8, and associated components.

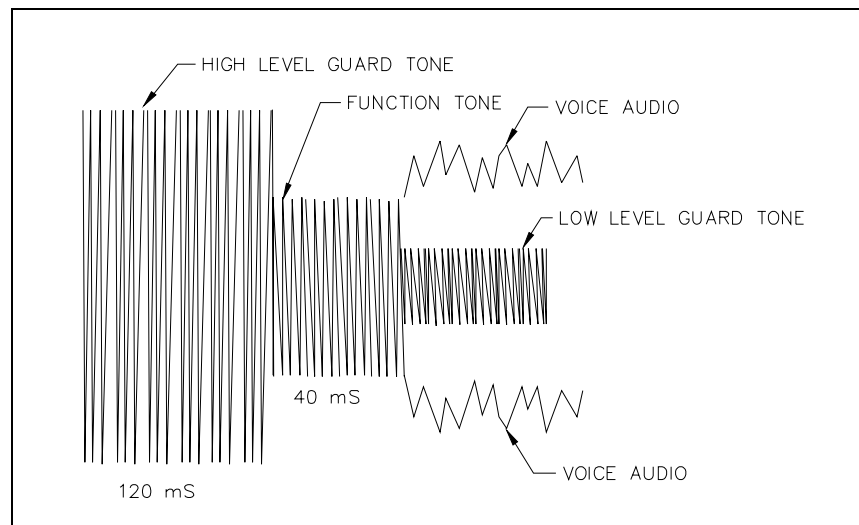

Audio at TPC1, the compressor output, is notch-filtered to ensure that LLGT is not heard while listening to transmissions from parallel desk sets. The notch filter consists of U10a, U10b, U10c, POT1 and associated components. Wire line audio at TPN, the notch filter output, is then gated to amplifier U13b where it is summed with any required tones (such as volume beeps) from the microcontroller. At the output of U13b, audio is fed to speaker amplifier U15. Also, the signal can be gated to the handset earpiece. Earpiece volume is adjusted through POT5.

The microcontroller selects the active microphone based on the state of the hookswitch. Microphone audio is scaled through U12d and gated to the compressor circuit consisting of U11, Q8, and associated components. Microphone audio at TPC1, the compressor output, is notch-filtered to ensure that voice components in the 2175 Hz range do not interfere with LLGT. Microphone audio at TPN, the notch filter output, is then gated to amplifier U12c where it can be summed with LLGT. POT4 adjusts the line output level. The output of U12c is gated to line driver U14 and transmitted over the wire line.

Each control tone frequency is synthesized as a square wave by microcontroller U1. This signal is then scaled to the correct amplitude at inverting amplifier U19a. By means of outputs PA5 and PA6, the microcontroller selects either high level, function tone level, or low level. The scaled square wave is smoothed into a sine wave by filter U19d. The resulting tone is gated either to U12c (if it is a control tone) or U13b (if it is a volume beep).

Speaker Volume Control

The actual speaker output level adjustment is done internally within power amp U15. The control circuit for this provides a precise control voltage connected to pin 5 of U15. The microcontroller examines the VOLUME Up/Down button presses and provides control pulses to electronic pot U9. U9 provides a variable reference voltage into the divider resistors (R156, R157, R158, R159) connected to U13 pin 12.

Speaker muting voltage is also connected to this divider through R154. If the dc volume control voltage at U15 pin 5 is below 0.3 V dc, the speaker amplifier switches to the mute mode. A dc volume control voltage greater than 1.6 V dc results in maximum gain of the amplifier U15.

Power Supplies

The power supplies for the desk set operate in the linear series-pass mode. Programmable Zener U7 serves as reference for the 5 V digital and analog power supplies. The reference voltage is 5.00 V dc, +/-0.1 V dc measured at U7 pin 1. Op-amp U8a controls the series pass element Q12 to provide 5 V dc at the 5 VD source point at C60, C61. The 5 VA supply is low-current and is fully implemented by U8b.

The VOS power supply, used to power the op-amp rails, is regulated to be approximately 11.2 V dc. The voltage level of the VOS supply is approximately 1.2 V above the 10 V (nominal) CMOS switch power supply. The reference for VOS is the 5 VD output. The divided output sample (through R178, R179, and R180) is compared to the reference at Q14 which serves as the control element for the series pass transistor Q13.

Switching regulator U20 is configured as a “boost regulator” in order to generate an 18 V source from the 12 V input. The 18 V source provides the reference for the line driver amplifier U14. A voltage divider (R5, R189, R114, and R162) sets the output voltage. The RC network of C85 and R191 is used for frequency compensation.

Line Select

Depressions of the F4/LS button cause a high at U6-5. This causes the collector of Q18 to toggle, thus activating or deactivating relay K1 and selecting Line 1 or Line 2. A high at U6-5 selects Line 2, a low at this pin selects Line 1. Diode D21 absorbs the reverse EMF that occurs when the transistor is switched off.

Troubleshooting the ITR1000-001 Basic Tone Remote Desk Set

The following is a list of potential problems you may encounter and possible solutions.

Problem	Possible Solution
General problems.	Ensure that there is a valid circuit line path from the desk set to the tone remote adapter.
	Ensure that the private circuit is balanced by making sure neither side of the telephone line is grounded.
	Check for a blown fuse and ensure that the desk set is connected to a properly functioning ac or dc (if using a dc power supply option) power source.
The desk set will not cause the tone remote adapter to key the radio.	Ensure that the proper tone adapter function tone for keying the radio is programmed into the desk set. Refer to the tone adapter service manual for valid function tones that will key the radio.
	Ensure that the desk set output level is set properly, and that the HLGTT is set in a range of 0 dBm to -10 dBm into the telephone line. Assuming no more than 20 dB of line loss on the telephone line, this level should be adequate for the tone adapter to decode the tone sequence.
RX audio is low or distorted.	Ensure that the tone remote adapter is wired correctly, including the RX audio pair. Audio quality is limited by the quality of the private radio circuit or leased lines between the station radio equipment and the remote dispatch point(s). In some cases, equalization of the lines or line conditioning may be required to ensure a reasonably flat line.
	Ensure pot 3 is set correctly. <ul style="list-style-type: none"> • Too high sensitivity overdrives the unit and results in distorted receive audio. • A setting that is too low results in low speaker or handset audio.
	If the internal speaker audio is adequate and only the earpiece is low, check the handset level pot 5 setting. See the Settings and Adjustments section in the Installation section of this manual.
There is continuous noise in the receive audio.	<p>The tone remote adapter must be connected to a muted and de-emphasized receive point in the station receiver.</p> <p>If receiver audio is derived from a detector or discriminator, continuous noise is heard unless the tone remote adapter has an internal squelch circuit.</p> <p>Refer to the station and tone remote adapter manuals for more information.</p>

Problem	Possible Solution
No receive audio on local speaker or handset.	Ensure that the tone remote adapter is supplying audio onto the private circuit.
	Ensure that the desk set's local speaker is not muted. Muting is indicated by a flashing frequency button.
There is no TX audio.	Check to be sure that station transmitter is keyed when PTT is applied from the desk set. If it is not, refer to the tone remote adapter or station manual.
Low TX audio.	Verify that the desk set's transmit output level is properly set and ensure that there is no more than 20 dB of loss in the private or leased line, which can cause degradation of the audio signal.
	If a leased line is being used and excessive losses are measured, contact your local exchange carrier. Check the pot 4 setting.
Distorted TX audio.	Verify that the tone remote adapter's transmit audio output level is properly set to match the station's rated transmit sensitivity. Refer to the station and tone remote adapter manuals for proper setup procedures.
No audio on local speaker.	Ensure that the volume is not turned down all the way, and the handset is on-hook. If receive audio is not switched to the local speaker when the handset in on-hook, the handset may be defective or have a defective magnetic reed switch.
	The local speaker is muted. (Indicated by a flashing frequency button.)

Fuse Replacement



For continued safe operation, replace fuses with the same type:

- **F1 is a Bussmann GMA 750mA fuse.**
- **F2 is a Bussmann C515S 1.25A SB 2AG fuse.**

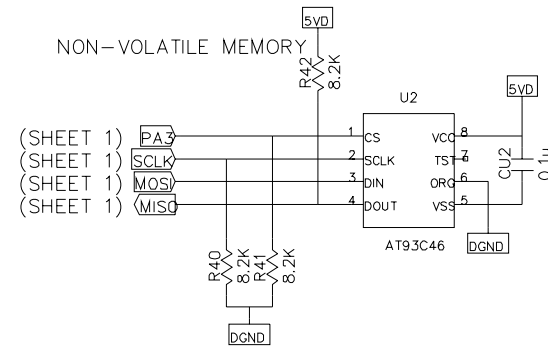
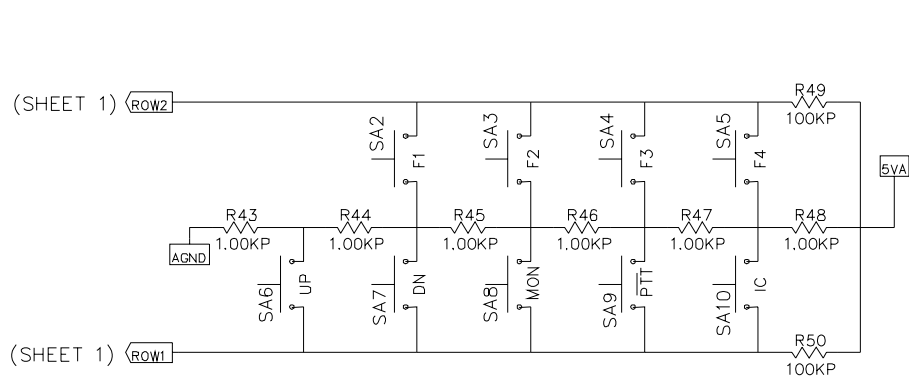
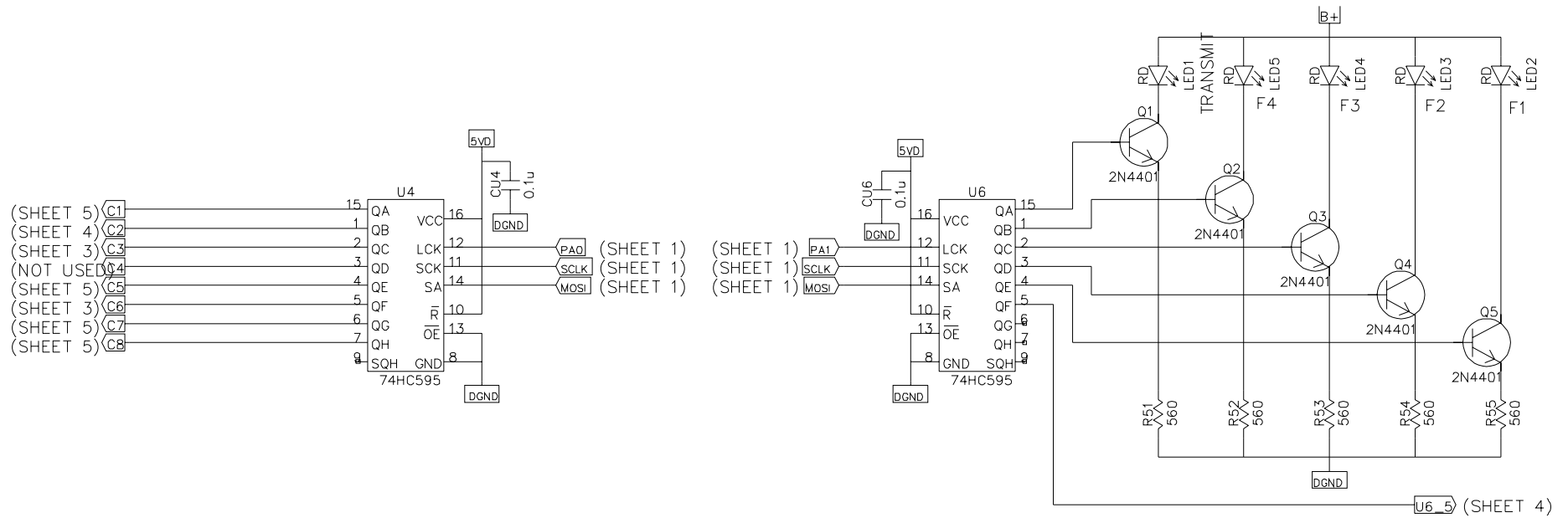

Tone Desk Set I/O Section Schematic Diagram - Sheet 2

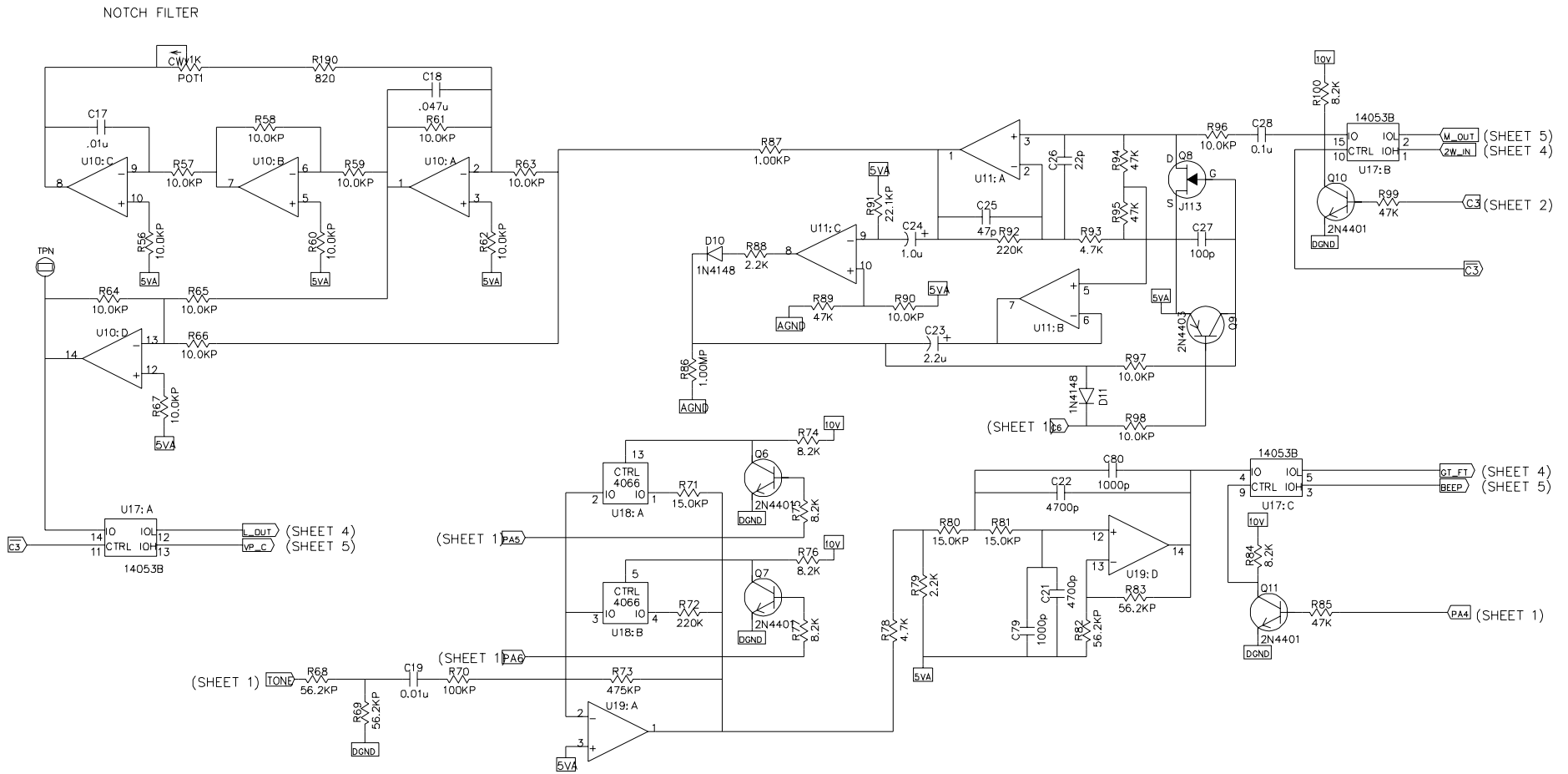

Tone Desk Set Audio Section 1 Schematic Diagram - Sheet 3

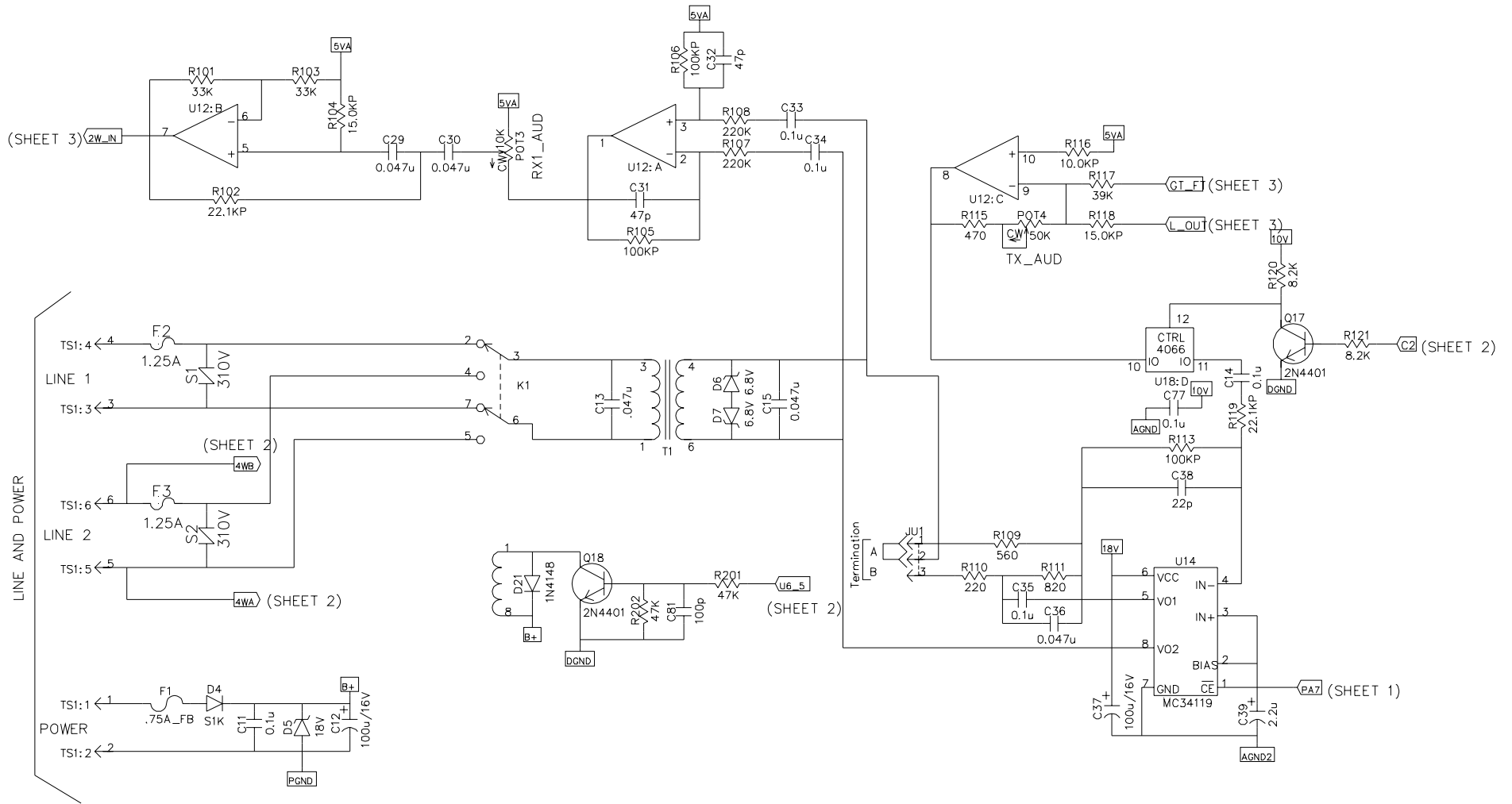

Tone Desk Set Audio Section 2 Schematic Diagram - Sheet 4

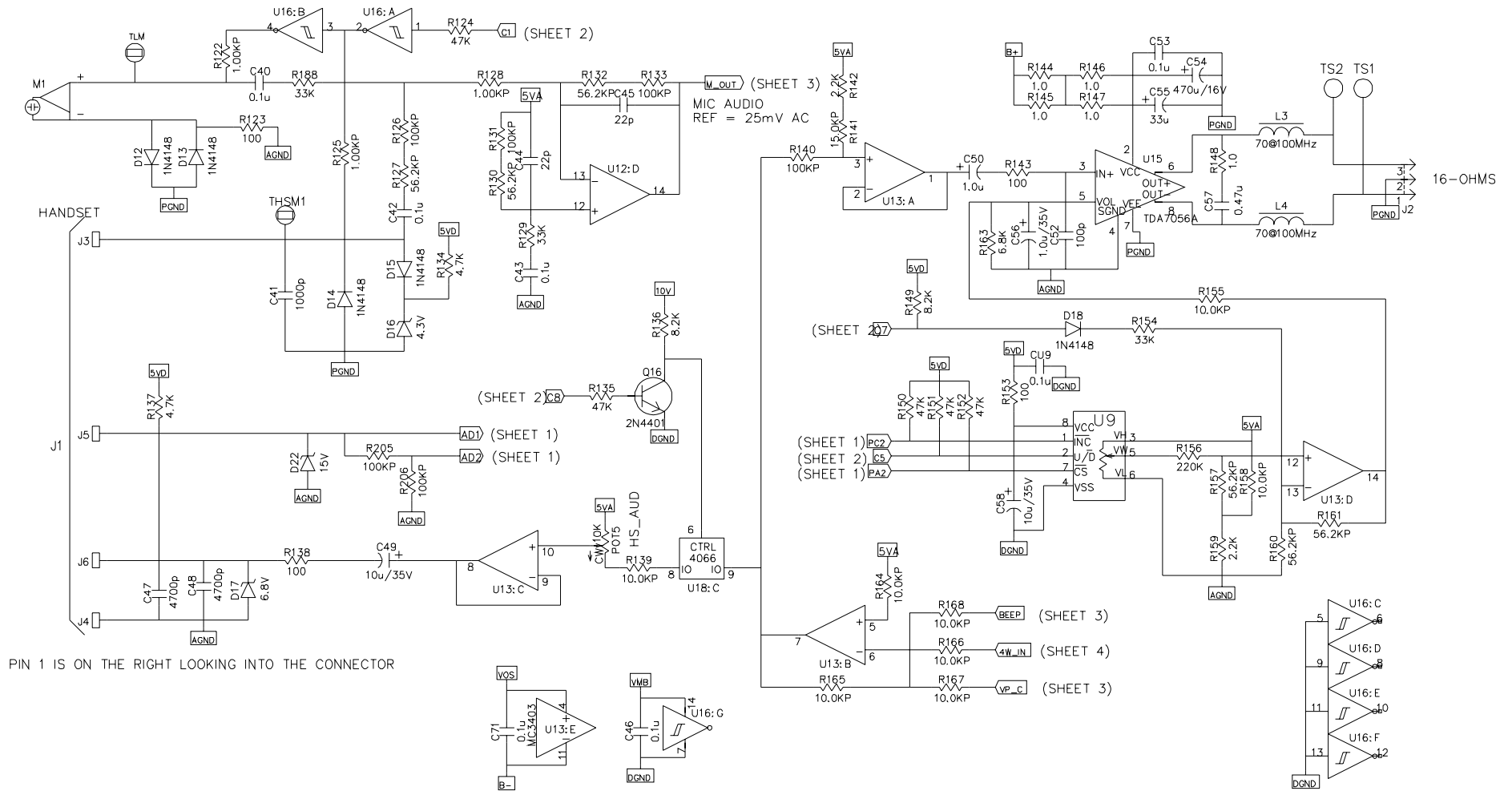

Tone Desk Set Audio Section 3 Schematic Diagram - Sheet 5

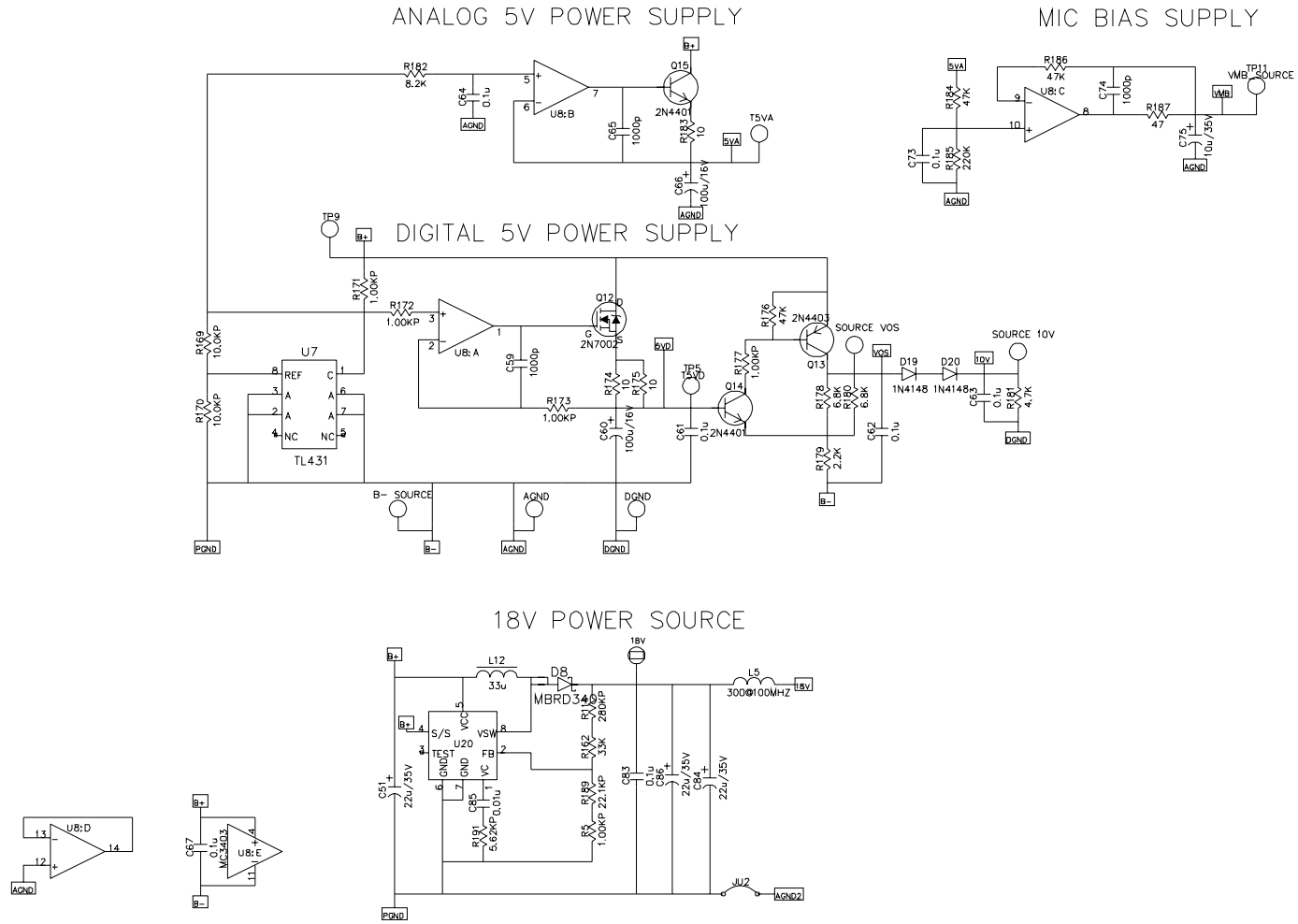

Tone Desk Set Power Supply Schematic - Sheet 6

Definitions and Acronyms

Term	Definition
CSQ	Carrier squelch
CTCSS	A means of grouping users of a common radio channel. Subaudible tones are transmitted with audio; a particular radio's speaker (or the speakers of a group of radios) will unmute to broadcast a transmission only if the associated subaudible tone identifies it as belonging to the radio's user group.
CDCSS	A system analogous to CTCSS but using low speed digital signaling instead of subaudible tones.
HLGT	High level guard tone
LLGT	Low level guard tone
PTT	Push-to-talk

