

FEMCO DIVISION
GULTON INDUSTRIES, INC.

MAINTENANCE MANUAL
FOR
PERMISSIBLE LOUDSPEAKING MINE TELEPHONE
821301/302
AM7021

DO NOT CHANGE WITHOUT APPROVAL OF
MINE SAFETY AND HEALTH ADMINISTRATION
(M.S.H.A.)

Copyright, Gulton Industries, Inc., 1982

821301-02.7
MAY 1983

TABLE OF CONTENTS

	Page
SECTION 1 - GENERAL DESCRIPTION -----	1/1
Introduction -----	1/1
Permissible System -----	1/1
Specifications -----	1/1,2
Installation -----	1/3
Block Diagram 821301/302 AM7021 -----	1/4
SECTION 2 - CIRCUIT ANALYSIS -----	2/1
Introduction -----	2/1
Block Diagram -----	2/2
Circuit Description -----	2/3
Schematic - Permissible Loudspeaking Mine Telephone, 821301/302 AM7021 -----	2/4
SECTION 3 - MAINTENANCE -----	3/1
Introduction -----	3/1
Troubleshooting Charts -----	3/2
SECTION 4 - PARTS IDENTIFICATION -----	4/1
Introduction -----	4/1
General Assembly - 821301/302 - Permissible Loud- speaking Mine Telephone -----	4/2
Assembly - WBA4097 - Permissible Loudspeaking Mine Telephone Printed Circuit Board -----	4/3
Assembly List - WBA4097 - Permissible Loudspeaking Mine Telephone Printed Circuit Board -----	4/4
Assembly - MI2806 Carbon Handset -----	4/5

SECTION 1

GENERAL DESCRIPTION

INTRODUCTION

The Permissible Loudspeaking Mine Telephone, AM7021 is designed to be used in mines where permissible devices must be used, as specified by mining laws. Two 12VDC batteries are used during the paging operation to produce the required 12VDC keying voltage on the phone lines. Provisions are made to keep the unit's speaker quiet when paging or receiving a normal audio signal. Input phone line DC polarity does not have to be observed since the unit's design provides for polarity reversal. Individual volume controls are provided for the speaker and handset receiver. This unit offers higher impedance for both AC and DC operation than other models and allows many units to operate on the same phone lines.

PERMISSIBLE SYSTEM

For a system to be permissible, all phones connected to the same phone line must be permissible units.

SPECIFICATIONS

The electrical, mechanical and environmental specifications for the unit are as follows:

ELECTRICAL:

Power Source ----- Two 12VDC NEDA 926 batteries or equivalent

Battery Requirements ---- a. Standby - 0 milliamperes.

b. Speaker Amplifier - 28 milliamperes at standby and 250 milliamperes for peak operation.

c. Handset Amplifier - 110 milliamperes nominal into 200 ohms (Varies with phone lines and number phones.)

Phone Line ----- 17K ohms DC, 4.5K ohms @ 1 KHZ. (Allows operation of many units on the same phone lines.)

Paging Voltage ----- 12 VDC

Paging Sensitivity ----- Solid State - pick up at 2.5 VDC or greater, drop out at 2.0 VDC.

Paging Switch ----- Bat handle.

Speaker ----- 3 watt, 8 ohm, 4" water-proof cone

Handset ----- Standard handset with push-to-talk switch and 4 foot of coiled cord.

Controls ----- a. Speaker Amplifier R15 adjustable
to 30 dB.

b. Handset Receiver R16 adjustable
to 30 dB.

Output Power ----- a. Speaker Amplifier - maximum of 2 watts
into 8 ohms (clipped).

b. Handset Amplifier - 380 milliwatts
into 200 ohm load.

Short Circuit Paging
Current ----- 0.35 amperes

Insulation ----- 600 VDC between line and ground.

Carrier Impedance ----- a. Line-to-line - 7K ohms.

b. Line-to-ground - 100K ohms.

MECHANICAL:

Dimensions ----- 6.68" width, 15.41"H, 5.00" depth

Weight ----- 15 lbs 8 oz. with batteries

Construction ----- 18 gauge stainless steel

Connections ----- Spring loaded push terminals for
phone line (2)

ENVIRONMENTAL:

Moisture Resistance ----- 0 to 95% humidity with printed circuit
board conformal coated.

Temperature Range ----- -30°C to +60°C.

INSTALLATION

One (1) 1/4 mounting slot is provided in the bottom center of the back plate and three (3) key punched holes are provided at the top of the back plate for mounting the unit to a wall, pole, desk or other similar structure.

Install battery and properly make all connections.

A fused station protector, FU2590, should be installed approximately every two miles on the phone line to protect against high voltage transients to ground.

WARNING: THIS TELEPHONE MUST NOT BE CONNECTED TO A NON-PERMISSIBLE TELEPHONE OR TO A PERMISSIBLE TELEPHONE DESIGNED TO OPERATE OR PAGE AT VOLTAGES OTHER THAN 12 VDC.

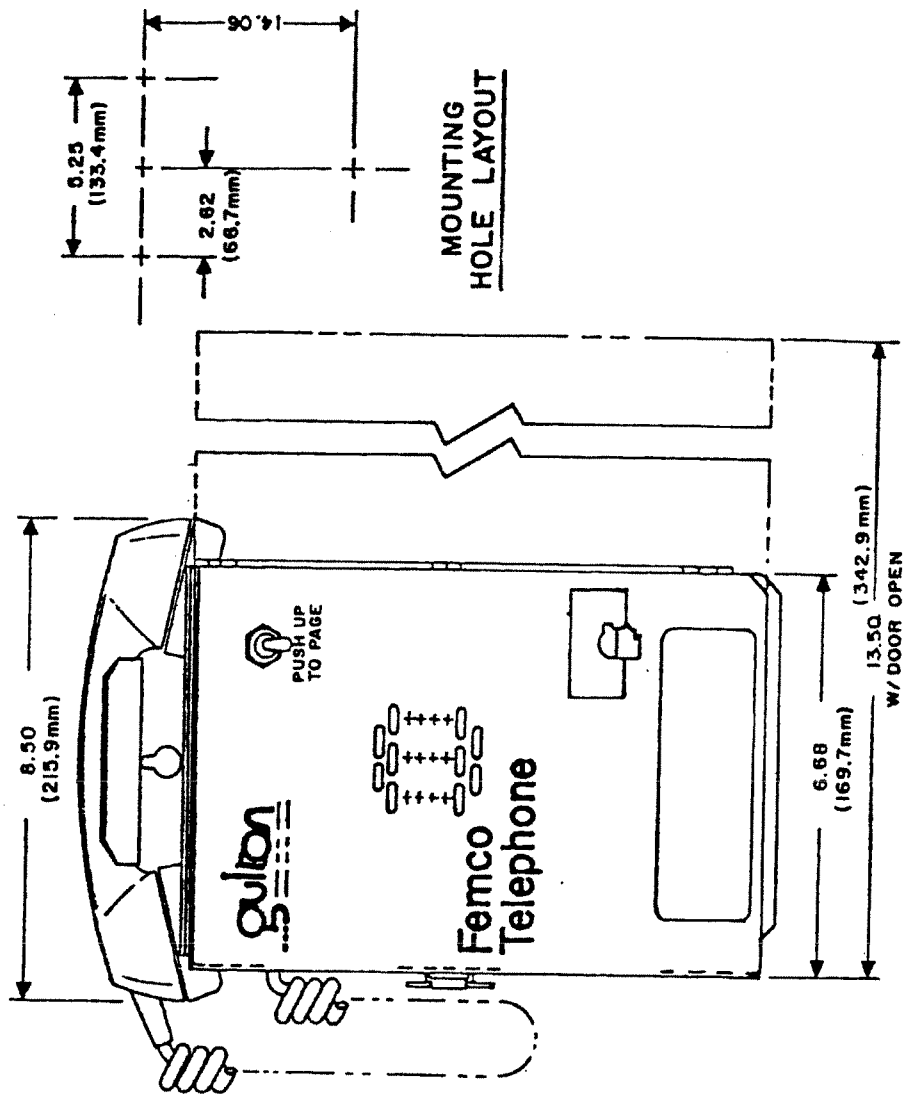

OUTLINE AND MOUNTING DIMENSIONS - Permissible
 Mine Telephone 821301/302 AM7021

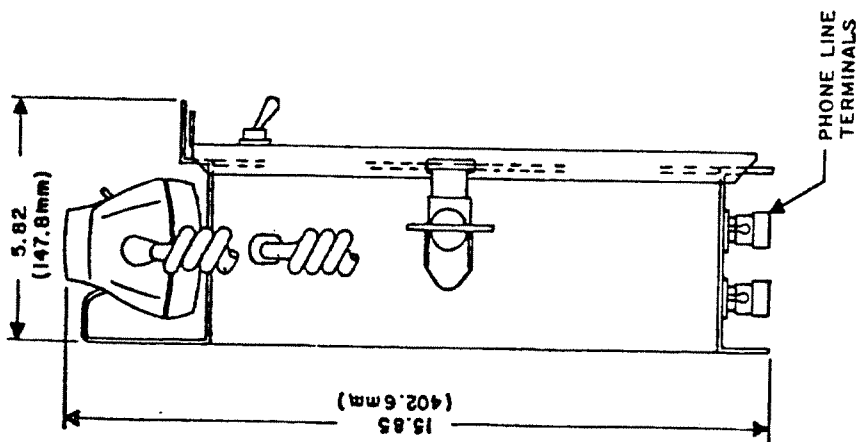

SECTION 2

CIRCUIT ANALYSIS

INTRODUCTION

This section of the manual is provided for acquainting maintenance personnel with the circuit operation of the unit. A block diagram is discussed to show the general operation of the unit. In addition, the schematic diagram is shown in order to explain the operation of the various components that comprise the unit.

BLOCK DIAGRAM

Refer to Figure 2-1. Section A discusses the unit operation when receiving a page and when receiving an audio signal during normal conversation. A DC voltage is imposed on the phone line by the paging party from a distant unit. This is full wave bridge rectified which handles any polarity reversal on the phone line. The rectified DC voltage allows Q2 to conduct which in turn, allows Q3 to conduct. When Q3 conducts, it allows IC1 to operate and amplify the audio signal. When being paged, the audio signal is transformer coupled through T1 and amplified by IC1 before passing to the speaker. The volume is adjusted by the SPEAKER VOLUME CONTROL. During normal conversation and when not being paged, there is no DC voltage imposed on the lines. This cuts off Q2 and Q3 which, in turn, prevents IC1 from amplifying any audio signal and passing it to the speaker. The audio signal is now transformer coupled through the HANDSET VOLUME CONTROL, to the handset receiver where it is heard by the operator.

Section B discusses the unit operation when paging another operator or when transmitting during normal conversation. When not paging, but speaking during normal conversation, BA1 and BA2 are connected through switch SW1. This allows the 12 VDC to pass through the handset switch and permits Q1 to conduct. When Q1 conducts it cuts off Q2 which, in turn, cuts off Q3. With Q3 off, IC1 is prevented from applying any audio signal and passing it to the unit's speaker. When the operator speaks into the handset, the audio signal is amplified by IC2 and transformer coupled by TR1 to the phone lines.

When paging, the operation just discussed still occurs. However, BA1 and BA2 are connected through SW1, which is now activated, and applies the 12 VDC keying voltage to the phone lines. Extra protection takes place to insure no audio signal reaches the unit's speaker. This is also done through the activated SW1 switch, which removes the positive voltage from Q3 further insuring IC1 is inoperative.

CIRCUIT DESCRIPTION

Refer to Figure 2-2. This is a schematic diagram of the unit. When the unit is being paged by another operator on the line, a DC voltage is imposed across terminals 8 & 9. Polarity does not have to be observed since diodes CR1 and CR4 comprise a full wave bridge rectifier that sets the correct polarity. Positive is applied to the base of transistor Q2 which allows it to conduct. When Q2 conducts, transistor Q3 goes into conduction which, in turn, allows the audio amplifier IC1 to operate. The audio signal is applied across the secondary of transformer T1 and transformer coupled to the primary. It then passes through R15, the speaker volume control, to be amplified by IC1. The amplified audio signal is now passed to the speaker.

When receiving a message during normal conversation, there is no DC voltage imposed on the phone lines. Transistor Q2 and Q3 are now cutoff which, in turn, prevents the audio amplifier, IC1 from operating and passing any audio signal to the unit's speaker. The audio signal that is now transformer coupled by T1, passes to the handset receiver through R16, the handset volume control.

When speaking to another operator on the phone line, the operation is as follows: BA1 and BA2 are connected through the N/C contacts of the PAGE switch, SW1. When speaking, the handset switch is depressed. This places a DC voltage at the base of transistor Q1, allowing it to conduct. When Q1 conducts, Q2 is cutoff which, in turn, cuts off Q3. When Q3 is cutoff it prevents IC1 from operating. No audio signal can reach the speaker at this time. The audio signal generated in the handset transmitter is amplified by the audio amplifier IC2 and transformer coupled by T1 to the phone lines.

When paging another party on the line, the operation just discussed still takes place. For additional protection, to insure no audio signal reaches the unit's speaker, the activation of the PAGE switch removes the positive leg of the operating voltage from the emitter of Q3, insuring it cannot conduct.

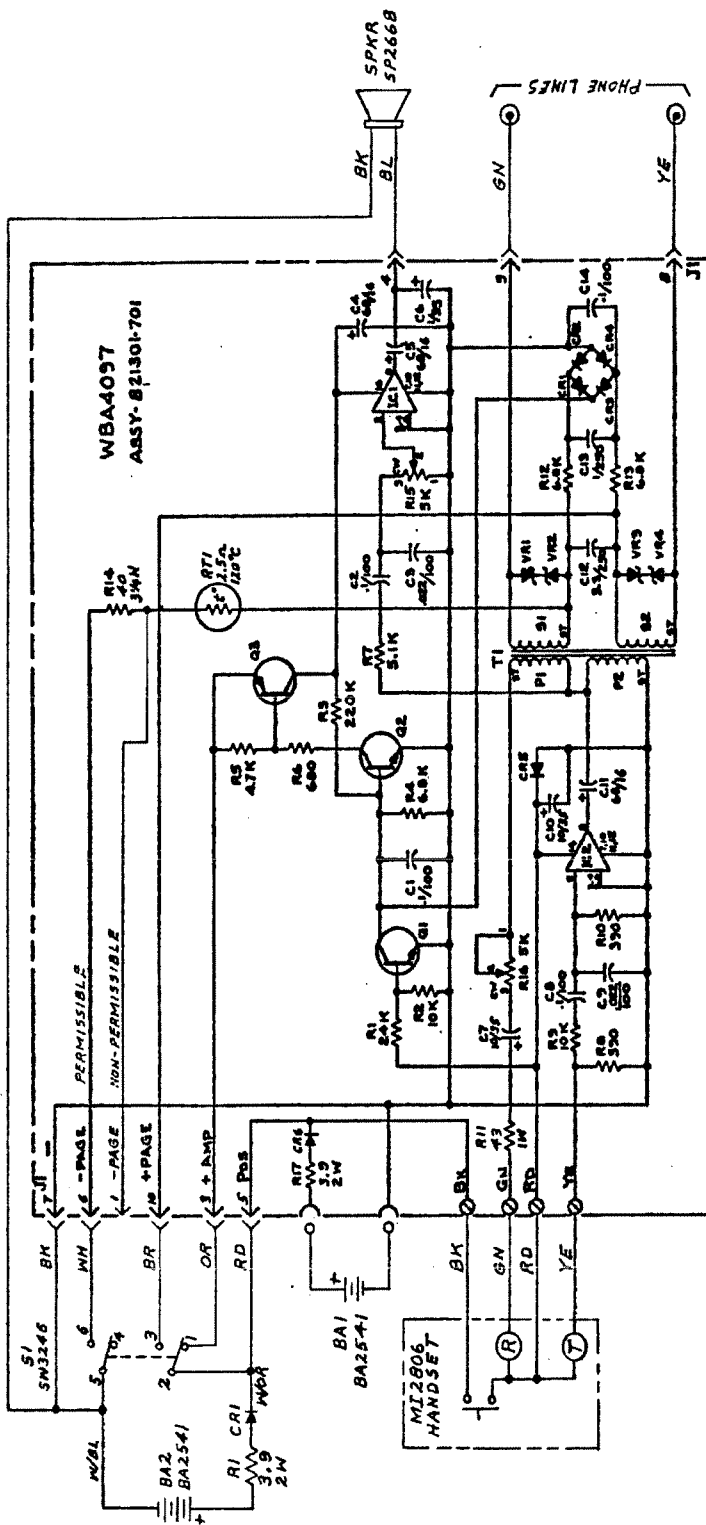

FIGURE 2-2 SCHEMATIC OF PERMISSIBLE LOUDSPEAKING MINE TELEPHONE
821301/302 AM7021

SECTION 3
MAINTENANCE

INTRODUCTION

This section of the manual contains information pertaining to the maintenance of the unit. Troubleshooting charts are provided to help in localizing the problem areas. Before any serious maintenance is considered, however, replace the battery to insure the correct operating voltage.

TROUBLESHOOTING CHARTS

The following troubleshooting charts are provided to assist maintenance personnel in localizing the general problem areas. Each chart contains three columns which are Symptom, Probable Cause and Remedy.

SYMPTOM	PROBABLE CAUSE	REMEDY
When receiving a page, phone lines are keyed by 12 VDC but there is no operating DC voltage for transistor Q2.	Diode CR1 and/or CR2, CR3, CR4 is defective	Replace diode CR1 and/or CR2, CR3, CR4.
DC operating voltage OK but when receiving a page, audio does not reach speaker.	Transistor Q2 is defective.	Replace transistor Q2.
	Transistor Q3 is defective.	Replace transistor Q3.
	Integrated circuit IC1 is defective.	Replace integrated circuit IC1.
	The speaker volume control (R15) is misadjusted.	Re-adjust the speaker volume control (R15).
When receiving a normal message but not being paged, audio does not reach operator.	Transformer T1 is defective.	Replace transformer T1.
	Handset volume control (R16) is misadjusted.	Re-adjust handset volume control (R16).
	Receiver element in handset is defective.	Replace receiver element in handset.

SYMPTOM	PROBABLE CAUSE	REMEDY
When paging another party, correct 12VDC is not imposed on phone lines.	Batteries BA1 and BA2 are weak or defective	Replace batteries BA1 and BA2
	The PAGE switch, SW1 is defective.	Replace PAGE switch.
When paging another party or transmitting during normal conversation, no audio signal is produced.	Transmitting element in handset is defective.	Replace transmitting element in handset.
	Integrated circuit IC2 is defective.	Replace integrated circuit IC2.
	Transformer T1 is defective.	Replace transformer T1.

SECTION 4
PARTS IDENTIFICATION

INTRODUCTION

The following information is presented to acquaint maintenance personnel with the procedure required for identifying parts. Normally, the parts identification is initiated by a breakdown of the major assemblies. The sub-assemblies, that comprise the individual major assemblies, are then reduced to their component parts. Each component part is identified by a circuit symbol, description and associated part number. Assembly and sub-assembly drawings are provided to facilitate in the part identification. In addition, reference can be made to the schematic in Section 2 of the manual if further identification is required.

For information on ordering parts, it is best to contact the local sales office to obtain the most current and expedient procedure.

GENERAL ASSEMBLY 821301/302 AM7021
 PERMISSIBLE LOUDSPEAKING MINE TELEPHONE

Ref. Dwg.: 821301-304, 821301-03.2

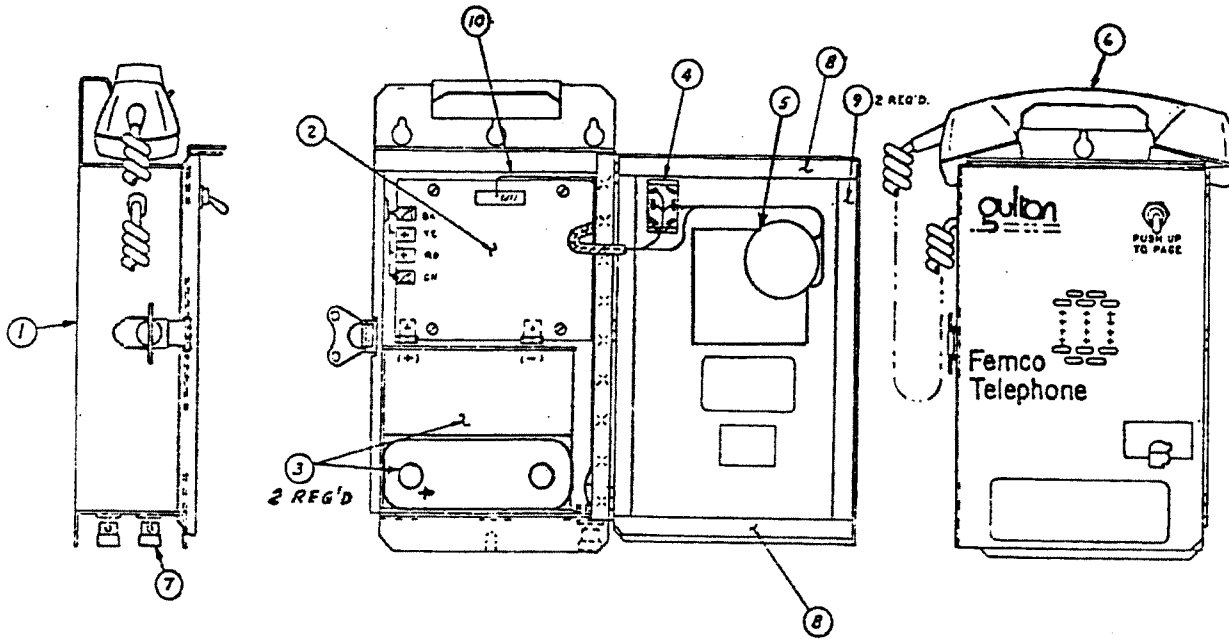

ITEM	PART NO.	DESCRIPTION
1	BO4721	Housing
2	WBA4097	Printed Circuit Board
3	BA2541	Battery (2 required)
4	SW3246	Switch
5	SP2668	Speaker
6	MI2806	Handset Assembly
7	TE2780	Binding Post
8	MC3589	Gasket 6-9/16"
9	MC3589	Gasket 11-3/4"
10	HA4024	Wiring Harness

ASSEMBLY-WBA4097 Permissible Loudspeaking Mine Telephone
 Printed Circuit Board

Ref. Dwg: 821301-701

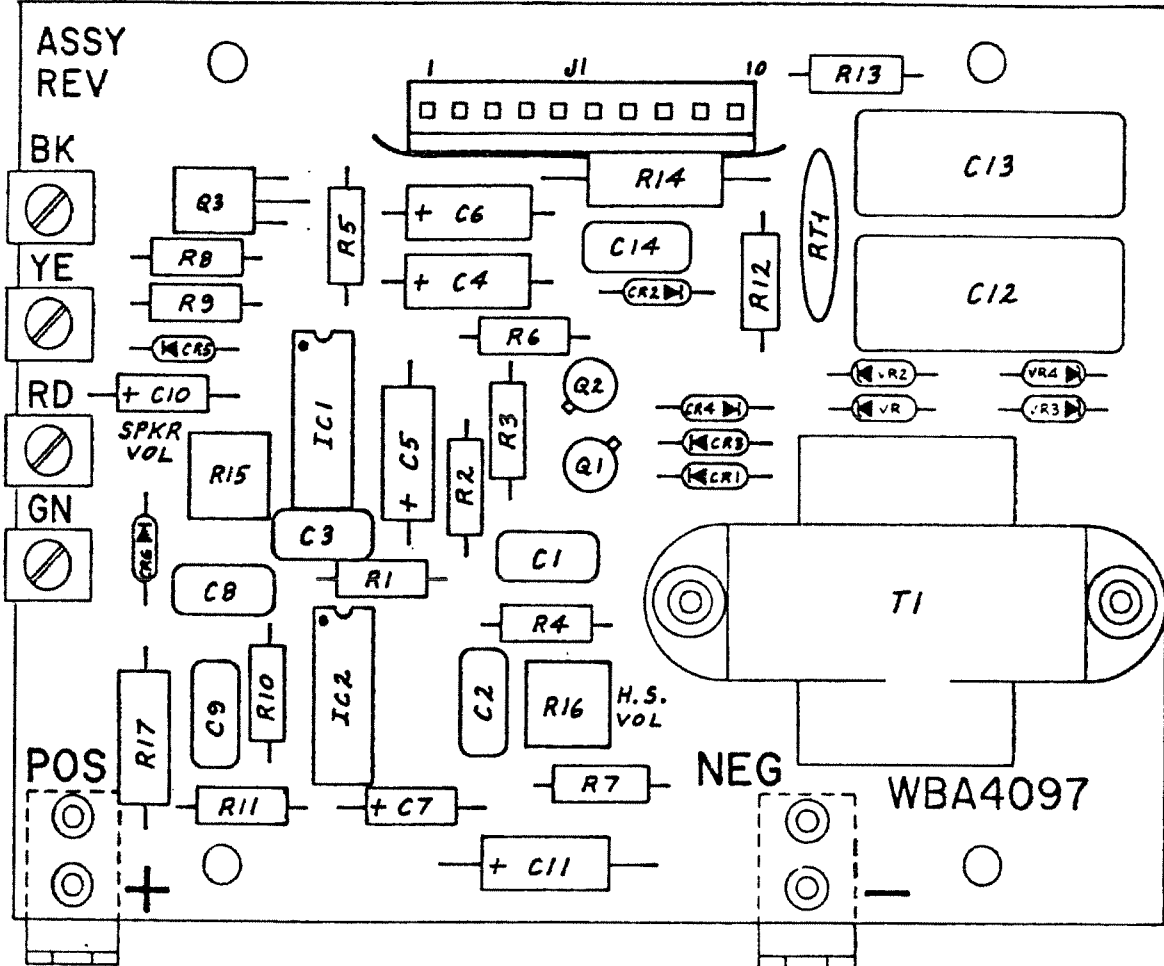

ASSEMBLY LIST-WBA4097
 PRINTED CIRCUIT BOARD

Ref. Dwg: 821301-801

CIRCUIT SYMBOL	PART NUMBER	VALUE
<u>Resistors</u>		
R1	RE24325	24K
R2,9	RE10325	10K
R3	RE22425	220K
R4,12,13	RE68225	6.8K
R5	RE47225	4.7K
R6	RE68125	680 ohm
R7	RE51225	5.1K
R8,10	RE39125	390 ohm
R11	RE3677	43, 1W, WW
R14	RE3551	40, 3 1/4W, WW
R15,16	RE3369	5K potentiometers
R17	RE3678	3.9, 2W, fusible
All resistors 1/2 W unless otherwise noted.		
<u>Capacitors</u>		
C1,2,8,14	CD3752	.1 uf, 100V
C3,9	CD3744	.022 uf, 100V
C4,5,11	CD3380	68uf, 16V
C6	CD3315	1 uf, 35V
C7, 10	CD3351	10 uf, 35V
C12	CD7036	3.3 uf, 250V
C13	CD7037	1 uf, 250V
<u>Diodes</u>		
CR1-5	TU2500	Silicon diodes
VR1-4	TU2692	Zener diodes
CR6	TU2685	Silicon diode
<u>Transistors</u>		
Q1,2	TU2750	Transistors
Q3	TU2604	Transistor
<u>Integrated Circuits</u>		
IC1,2	TU2605	Integrated Circuits
<u>Transformer</u>		
T1	TR3031	Transformer
<u>Miscellaneous</u>		
J1	CN3827	Connector
	MO4363	Battery Brackets
	NU2630	Screw Clips
<u>Thermistor</u>		
RT1	RE3676	2.5 ohm

ASSEMBLY - MI2806 Carbon Handset

Reference Drawings: 741301-703, 741301-803

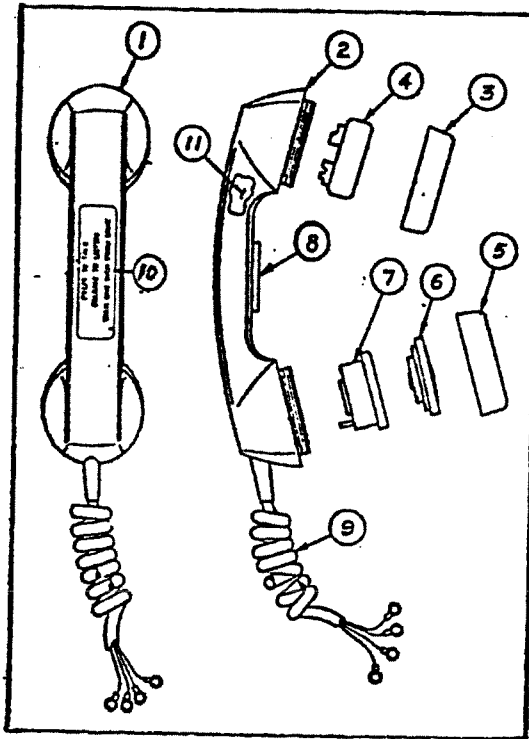

Item	Part Number	Description
1	MI2806	Handset Assembly
The following items are Renewal Parts for MI2806		
2	MI2775	Handset Handle
3	MI2776	Ear Cap
4	MI2707	Receiver
5	MI2777	Mouth Piece Cap
6	MI2625	Transmitter
7	MI2778	Cup Assembly
8	SW3358	Switch
9	MI2809	Koiled Kord 4-Conductor
10	NP2581A	Nameplate
11		Cotton

Warranty

Equipment. GAI-Tronics warrants for a period of one (1) year from the date of shipment, that any GAI-Tronics equipment supplied hereunder shall be free of defects in material and workmanship, shall comply with the then-current product specifications and product literature, and if applicable, shall be fit for the purpose specified in the agreed upon quotation or proposal document. If (a) Seller's goods prove to be defective in workmanship and/or material under normal and proper usage, or unfit for the purpose specified and agreed upon, and (b) Buyer's claim is made within the warranty period set forth above, Buyer may return such goods to GAI-Tronics nearest depot repair facility, freight prepaid, at which time they will be repaired or replaced, at Seller's option, without charge to Buyer. Repair or replacement shall be Buyer's sole and exclusive remedy, and the warranty period on any repaired or replacement equipment shall be one (1) year from the date the original equipment was shipped. In no event shall GAI-Tronics warranty obligations with respect to equipment exceed 100% of the total cost of the equipment supplied hereunder. Buyer may also be entitled to the manufacturer's warranty on any third-party goods supplied by GAI-Tronics hereunder. The applicability of any such third-party warranty will be determined by GAI-Tronics.

Services. Any services GAI-Tronics provides hereunder, whether directly or through subcontractors, shall be performed in accordance with the standard of care with which such services are normally provided in the industry. If the services fail to meet the applicable industry standard, GAI-Tronics will, for a period of one (1) year from the date of completion, re-perform such services at no cost to Buyer. Re-performance of services shall be Buyer's sole and exclusive remedy, and in no event shall GAI-Tronics warranty obligations with respect to services exceed 100% of the total cost of services provided hereunder.

Warranty Periods. Every claim by Buyer alleging a defect in the goods and/or services provided hereunder shall be deemed waived unless such claim is made in writing within the applicable warranty periods as set forth above. Provided, however, that if the defect complained of is latent and not discoverable within the above warranty periods, every claim arising on account of such latent defect shall be deemed waived unless it is made in writing within a reasonable time after such latent defect is or should have been discovered by Buyer.

Limitations / Exclusions. The warranties herein shall not apply to, and GAI-Tronics shall not be responsible for, any damage to the goods or failure of the services supplied hereunder, to the extent caused by Buyer's neglect, failure to follow operational and maintenance procedures provided with the equipment, or the use of technicians not specifically authorized by GAI-Tronics to maintain or service the equipment. THE WARRANTIES AND REMEDIES CONTAINED HEREIN ARE IN LIEU OF AND EXCLUDE ALL OTHER WARRANTIES AND REMEDIES, WHETHER EXPRESS OR IMPLIED BY OPERATION OF LAW OR OTHERWISE, INCLUDING ANY WARRANTIES OF MERCHANTABILITY OR FITNESS FOR A PARTICULAR PURPOSE.

Return Policy

If the equipment requires service, contact your Regional Service Center for a return authorization number (RA#). Equipment should be shipped prepaid to GAI-Tronics with a return authorization number and a purchase order number. If the equipment is under warranty, repairs or a replacement will be made in accordance with the warranty policy set forth above. Please include a written explanation of all defects to assist our technicians in their troubleshooting efforts.

Call 800-492-1212 (inside the USA) or 610-777-1374 (outside the USA) for help identifying the Regional Service Center closest to you.